

Cultivating Learning with School Gardens

Primary School Level





This project was funded by the United States Agency for International Development's (USAID) African Education Initiative (AEI) and developed in partnership with the Republic of Congo's Ministry of Education, United States Department of Agriculture (USDA), International Partnership for Human Development (IPHD), University of Wisconsin–Extension (UW-Extension) and Bay Mills Community College. As such, the agricultural practices in this manual were designed for the environment and climate of the Republic of Congo and may need to be adapted for local agricultural conditions. It is recommended that users consult with local agricultural scientists about planting, irrigation, disease, fertilization and harvesting of school gardens from that region.

Major contributors include:

Janet Connelly, USDA

Mary Crave, Ph.D., University of Wisconsin–Extension

Dawn Danz-Hale, University of Wisconsin–Extension

Michael Doyle, Ph.D., Bay Mills Community College, Michigan

Gabriel Frigm, USDA

Jennifer Maurer, USDA

Jane Misheloff, Ph.D., USDA

Julie Polt, USDA

Carolyn Schramm, USDA

Chad Wesen, USDA

Thomas Syverud, University of Wisconsin-Extension

**4th Edition (Global Draft)
July 2009**

The U.S. Department of Agriculture (USDA) prohibits discrimination in all its programs and activities on the basis of race, color, national origin, age, disability, and where applicable, sex, marital status, familial status, parental status, religion, sexual orientation, genetic information, political beliefs, reprisal, or because all or part of an individual's income is derived from any public assistance program. (Not all prohibited bases apply to all programs.) Persons with disabilities who require alternative means for communication of program information (Braille, large print, audiotape, etc.) should contact USDA's TARGET Center at (202) 720-2600 (voice and TDD). To file a complaint of discrimination, write to USDA, Director, Office of Civil Rights, 1400 Independence Avenue, S.W., Washington, D.C. 20250-9410, or call (800) 795-3272 (voice) or (202) 720-6382 (TDD). USDA is an equal opportunity provider and employer.



USAID
FROM THE AMERICAN PEOPLE



Overview

School Gardens have four important objectives:

1. Provide a laboratory for experiential learning to complement the standard school curriculum in all disciplines.
2. Contribute to the government's focus on science, literacy, numeracy, and other educational priorities for both girls and boys.
3. Contribute to the intellectual, psychological, physical, and vocational development of the students through enhanced learning methods.
4. Increase parent and community involvement in the school and transfer skills and knowledge from the school garden to home and community.

There are two major sections to this manual, intended to be used together:

1. *Basic Components: Steps to Developing a School Garden*
2. *Help for Teachers: Bringing the School Garden into the Classroom*

In this manual teachers learn the basics of a school garden laboratory:

1. How to demonstrate the steps in planning, cultivating and tending a school garden.
2. Tips on making a school garden successful – including working with your community, parents, and other organizations.
3. How to develop child-centered activities that involve students in the school garden.
4. How to integrate the school garden into classroom lessons at the primary level. This includes lesson ideas in language, geography, mathematics, science, and social studies.

The primary expected outcomes of this project are as follows:

1. Increased enrollment and attendance rates at your school.
2. Increased student nutrition through the production of fresh fruits and vegetables.
3. Increased gardening skills and knowledge concerning gardening (including plant and environmental sciences.)
4. Increased parent and community involvement in your school.
5. Increased capacity of teachers to use the school garden as a learning laboratory for students.



Table of Contents

SECTION 1

Basic Components and Steps to Developing a School Garden 8

A. Introduction8

B. The Five Basic Steps11

1. Choosing a Site: Where to Put Your School Garden11

2. Preparing a Site: Choose Your Garden Design13

3. Planting the Garden20

4. Tending the Garden25

5. Harvesting, Preparing, and Eating the Food36

C. More Gardening Science45

1. Alternative Planting Methods45

2. Basic Plant Science49

3. Compost: A Recipe for Success in the Garden54

4. Future Plantings58

5. Agro Forestry65

6. Steps to a Healthy Garden66

D. Nutrition76

1. Types of Nutrients76

2. Types of Foods79



SECTION II

Help for Teachers: Bringing the School Garden into the Classroom81

A. Introduction to School Gardens81

- 1. Major Aims of School Garden Programs82
- 2. Major Benefits of School Gardens83
- 3. Core Beliefs and Convictions of School Garden Projects84
- 4. Elements Necessary for a School Garden Program86

B. Involving the Community in Garden Management87

- 1. Create a Garden Management Committee87
- 2. Build Community Support and Involvement with Open Door Events90

C. Experiential Learning Methods and Theory100

- 1. The Experiential Learning Cycle102
- 2. Demonstration Methods103
- 3. Classroom Aids105
- 4. Involve Students in the Garden111
- 5. Experiment in the Garden and Classroom114
- 6. Use Observation Skills120
- 7. Use Experiential Activities in the Gardens126
 - Guidelines for Teachers126
 - Lesson Recommendations127
 - Lesson Plan Framework for Teachers172

SECTION III

Appendices173

A. Classroom Posters175

B. Quick Gardening References177

C. Teacher Training Agendas and Evaluation Instruments183

D. Project Monitoring and Evaluation Instruments193

SECTION IV

References199

SECTION IV

Teacher Observations and Notes203

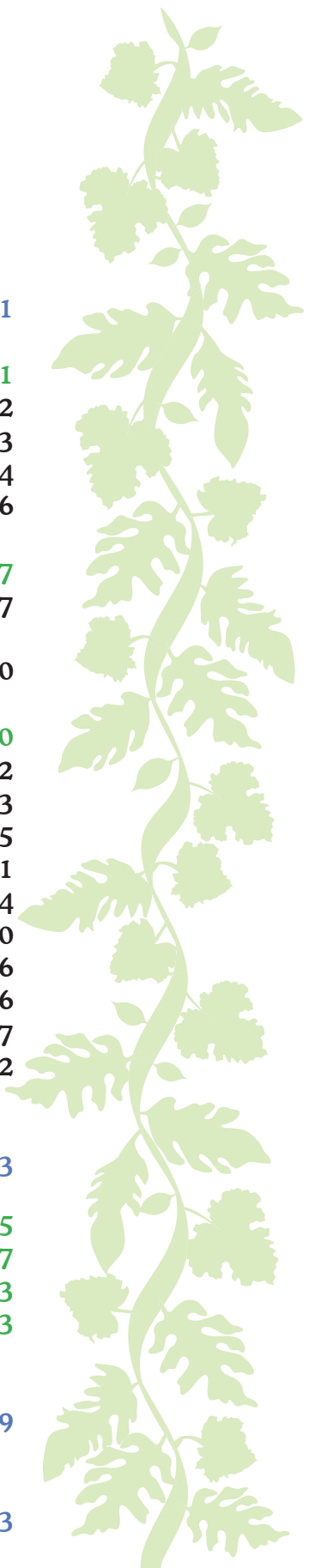



SECTION I

Basic Components and Steps to Developing a School Garden

A. Introduction

Gardening can be a fun and interesting way to help students learn. Meanwhile, of course gardens and their bounty help to improve food security. This curriculum is designed with these concepts at the forefront.

In some parts of the world many people cultivate land for food. In other areas few people are gardeners. That means some of the students and teachers may already know a lot about gardening. Meanwhile, most gardeners around the world are interested in learning how to produce more food with fewer resources and less labor. Fortunately, Africa is rich in land, rainfall, sunshine and other elements necessary for gardens.

People around the world prefer different gardening practices. These practices depend on the culture, climate, resources, habits, knowledge and skills of the people doing the gardening. Simply put: there are many correct ways to garden.

The techniques taught here can be used in any garden – for a household, a school, a group, or a community. You may consult with local gardening experts and incorporate gardening methods that you are familiar with and know are successful in addition to the recommendations in this guide.

School gardens have many benefits – and not just for the students who learn and work in them and those that enjoy the food produced. When students learn new gardening techniques, they can pass them on to their parents and households. Communities benefit in turn when their citizens work together to support the garden, and community members can learn by observing new techniques and experiments. Local organizations and school gardens can enhance and complement each others' programs in nutrition and health, income generation, and other social programs.

This curriculum and training is designed to address the challenges and benefits of school gardens. This section of the Manual will review some of the steps that are essential in developing a garden, and will introduce some new techniques that help you garden with limited resources while preserving your natural environment.

The Garden as an Ecosystem

Before you begin the process of developing and planting a school garden, first consider the garden as a system.

A garden is a complex system of interconnected parts. Some of these components are living organisms that flourish in healthy soil, such as cultivated plants and their living companions: microorganisms, earthworms, insects and numerous other life forms.

These living components interact with non-living factors such as water, minerals, gases (air), and heat to form a dynamic living system, commonly referred to as an "ecosystem." A garden is a miniature, human-made ecosystem. In natural ecosystems the removal of one component often negatively influences the entire system. This holds true in the cultivated garden as well. In other words, a garden is much greater than the sum of its parts.

Thinking of the garden as an ecosystem will help you and the students make good use of all your resources – human and non-human – and help you in making many decisions as you garden.

You can work to improve the garden system:

- Mulch and compost can turn barren soil into rich, fertile soil.
- Wet areas can be managed to help supply the rest of the garden with water.
- Animal manure can be added to compost.
- Unused plant material can be returned to the garden as compost or mulch.
- Old buildings can be used to support vine crops.

Meanwhile, there are many "automatic" benefits to the garden system that require no human intervention. Here are two:

- Birds eat insects, leave fertilizer and spread seed.
- Bushes produce food and can be used as a fence.



Observe! Observe! Observe!

Observation is the critical key to successful gardening. Work with nature instead of trying to force your demands on the land and plants.

Gardens are a system. Take time to become familiar with your land.

Learn the patterns of the sun, wind, water, insects, plants, wildlife and human life. Feel how the wind hits your skin, smell the earth, look for patterns, use your observation skills to become aware of how the system is already interacting and how it will be affected when you put in a garden.

You are the center of your garden!



B. The Five Basic Steps

A garden is created, managed, tended, and harvested by people. This section describes how to develop a school garden, and presents five basic gardening steps/techniques:

1. Choosing a site
2. Preparing the site
3. Planting the garden
4. Tending the garden
5. Harvesting, preparing and eating the food

In addition to these five steps, the section includes several pages on gardening science – techniques you may want to use in your garden and theory to help teachers understand the science behind gardening.

STEP 1

Choosing a Site: Where to Put Your School Garden

The function and purpose of your school garden will help you decide where to plant it. There are also some practical issues that should be considered.

Remember the main purposes of a school garden are to provide:

1. food for the students, and
2. a laboratory where the students can learn about, enhance and complement your lessons in science, mathematics, French, social studies and other academic subjects.

These should be the primary factors in deciding where to locate a school garden. You want a site that can grow enough food to supplement the school feeding program. It should also be located in a place and manner that is easily accessible. This will ensure that students and teachers can come and go quickly for lessons and learning activities, and to work in the garden.

It is important to arrange your school garden so that it becomes a living, functional system that is self-sufficient. Keep in mind that some locations are better than others. In addition to growing food and using the garden as a laboratory, you need to think about several important factors. These are detailed in the chart that follows.





Factors to Consider When Choosing a Garden Site

Water

You may have to carry water into the garden during dry periods. For that reason, locate the garden as close as possible to a natural source of water, such as a well or stream. In addition, is there another source of water nearby that you can use? For example, can you easily take advantage of collected rainwater or gray water (recycled water) nearby to water the garden? Keep in mind that any need to carry water will increase labor and may limit the practical size of the garden.

Sun

A garden needs at least 6 hours of full sunlight every day to grow good vegetables. Meanwhile, some plants do better in the shade and in cooler soil, so for these species some shade will be acceptable.

Topography

Is your garden on flat or sloping land? If on a slope, special techniques can be used to reduce erosion and retain water.

Traffic Patterns

Put the garden in a convenient spot so people can see it. It is easier to pick a weed or monitor progress if the garden is on a well-used path. Further, locate the garden as close to the school as possible to facilitate easy access for both students and school staff. In addition, the garden should be easy to enter and exit, and should be able to accommodate many people at once.

Safety

Safety is critical in a school garden. Consider any potential sources of injury and how these can be prevented. For example, if the garden has a well, is it covered?

Security

You want the community to support your garden; this support will help ensure that the garden is productive and secure from damage by stray or wild animals, theft, or vandalism. How visible should it be? Are there people who can help keep it safe on weekends and school holidays when the students and teachers are not around? In addition, you may need an additional barrier outside the garden fence to repel animals.

Factors to Consider When Choosing a Garden Site (continued)

Ownership

A successful school garden involves parents and the community as well as the students and teachers. Will the land be donated or lent to you? For how long? Do all ethnic groups consider the location appropriate and politically or religiously neutral?

Other _____? Can you think of other things that may influence the location of your garden?

STEP 2

Preparing a Site: Choose Your Garden Design

After you have found a location for your school garden, choose a design for the garden and prepare the soil for planting. There are many options for designing your garden:

a. Use Garden Beds Wisely

A low impact approach is the guiding principle for gardening. This means practices that do the least damage to the soil and surrounding natural resources. When we disturb the soil we can be destroying thousands of years of work by many different organisms. Try to minimize environmental impacts when designing and preparing your garden. You can even tuck your garden into the space available, conforming to the shape of the land rather than to a specific geometric shape.

Rectangle

For beginning school gardens, a rectangle is a simple design that also allows students to measure geometric shapes; this is a fun way to learn math concepts. The rectangle can be any dimension or a combination of dimensions that make the best use of the land available. A simple rectangular design is recommended for beginning school gardens.



Sloped Beds/Terracing

It is best to plant on flat ground, or at the bottom of a slope. High concentrations of nutrients are located there especially, because through time rain has washed over the soil above and nutrients have washed down the slope. If it is necessary to plant on the slope, try to mimic nature's pattern: place logs or rocks perpendicular to the slope to form a terrace. These built-up edges will hold the soil, and each bed should be perpendicular to the slope and parallel to flat ground. Terracing helps conserve water and nutrients which would otherwise run down the slope.

Raised Beds

About one month prior to planting, spread compost liberally (about 20 cm. high) in the area that you plan to cultivate. Just before planting, break the ground under the compost (about 10 cm. deep) and mix it with the overlying compost. Then form the raised beds as defined by your garden plan, adding new compost where necessary to build up the bed. This method creates very fertile soil which will produce healthy plants and promote high yields.

Trenched Beds

This is a solution to minimally impact the soil when there is a problem with water, be it a lack of water or an over-abundance of water. Dig trenches in a checkered pattern. Ideally the soil from the trench should be mounded up on the undisturbed soil to create a ridge about 30 cm. high.

Refer to *Gardening with Raised Beds* and *Gardening with Trenched Beds* in the section entitled *More Gardening Science*.

Terracing



Sloped Bed

If your soil is on a slope, heavy rains will cause severe soil erosion problems, and you will lose much of your valuable topsoil, the compost and the animal manures you've added to build your soil.



Raised Bed

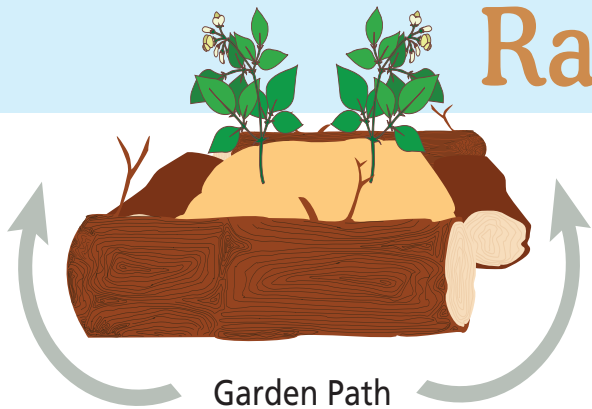

Trenched Bed

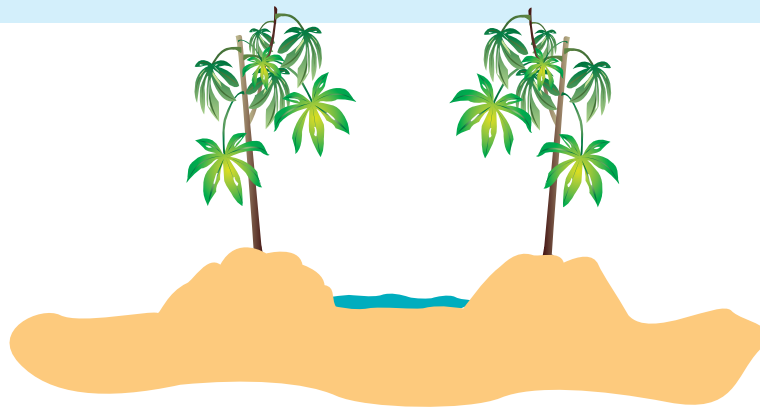

b. Maximize Use of Space

Trees, bushes, above-ground crops, and below-ground crops can all grow in the same area. You do not need a large garden! Instead, think of all the plants that can be grown in a small space. For example, in one small place you could climb a palm tree to harvest nuts, reach up to harvest papaya, and cut some cassava leaves. You could grow some ginger in the shade of these plants, cultivate yams so their vines crawl up the trees, and nurture peanut plants to carpet the ground. Sweet potatoes could grow there as well. This is called companion gardening (explained more fully on page 45). In addition to making good use of space, companion gardening provides natural pest control and promotes favorable growing conditions for each plant.

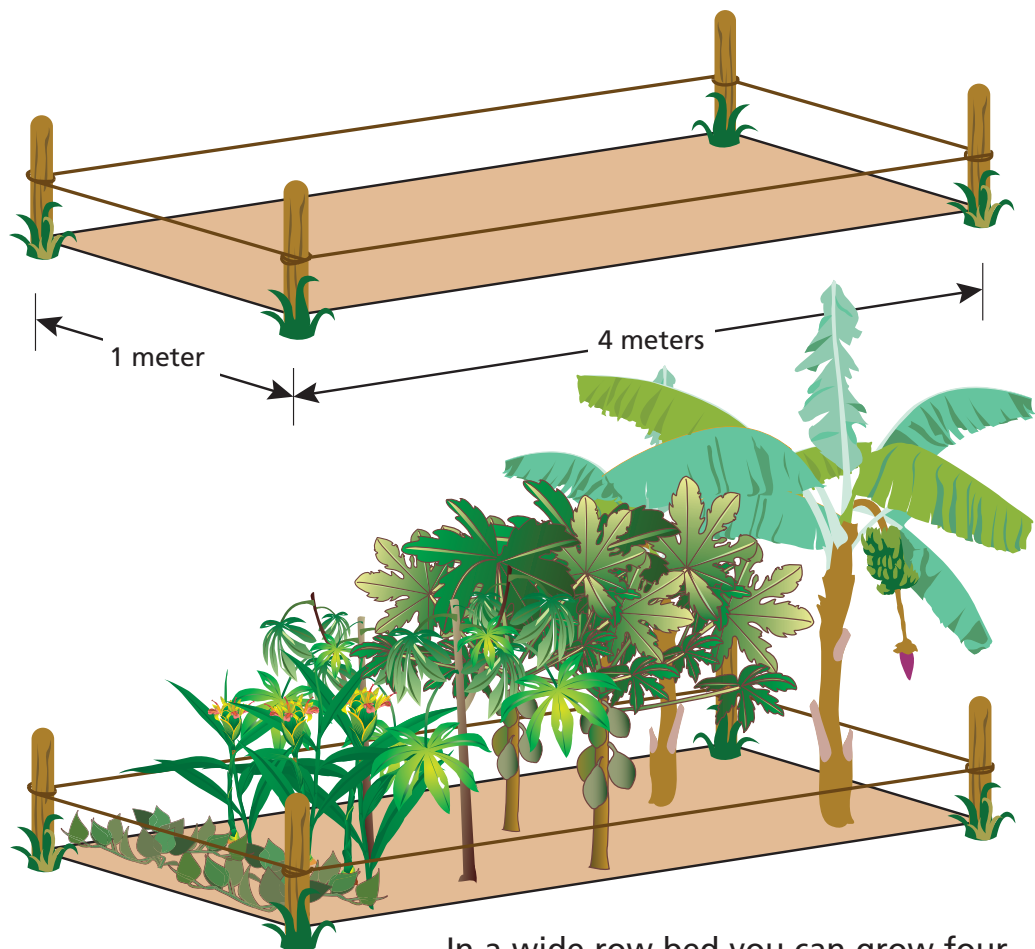

In a wide row bed you can grow four times as many vegetables as is possible in a conventional row garden.

c. Develop a Garden Plan

After considering as many variables as possible, construct a garden plan. Such a plan is a "map" of your proposed garden and should include information such as the following:

- size and dimensions of the garden
- how the garden is oriented in relation to the environment
- layout of the planting beds and crops to be planted in each

and the location of various resources:

- well/water source
- composting pits
- nursery/shade house
- fencing/barriers
- paths/access
- trees/bananas, vines, etc.
- shade tree(s) for rest area, etc.

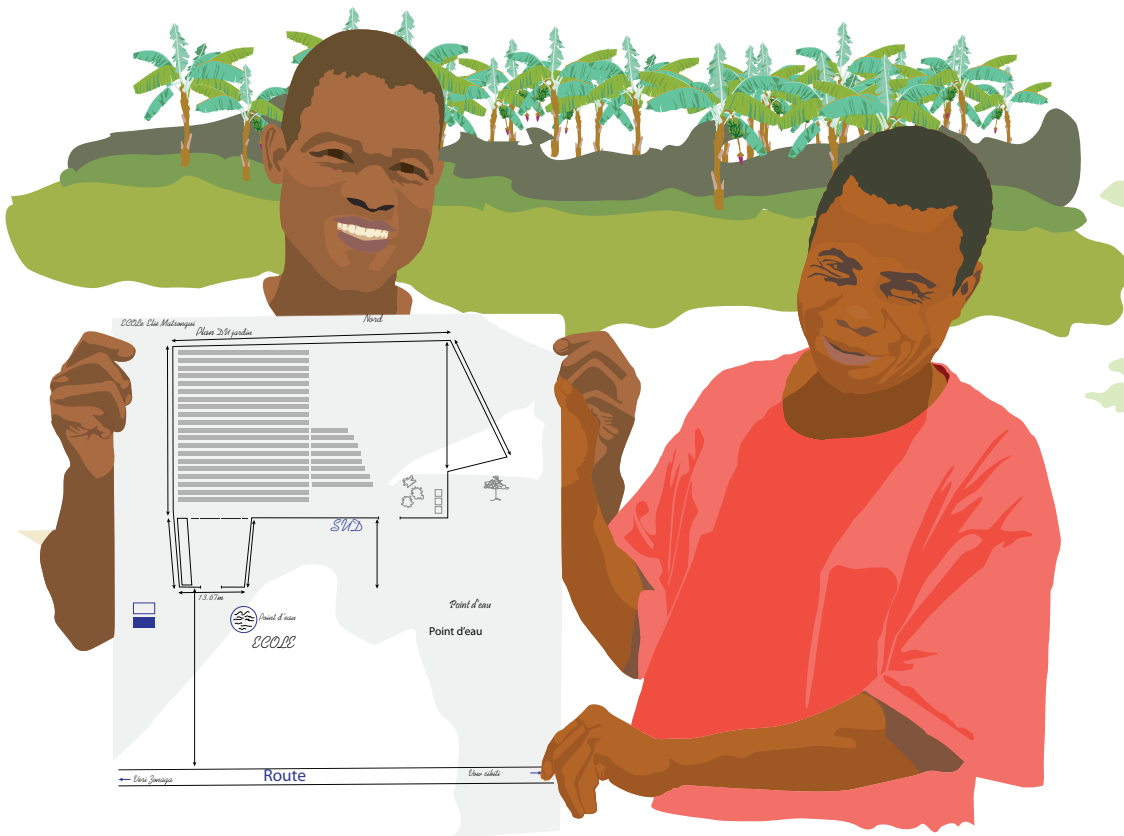



Design the Garden with your Students and Colleagues

There is no single best garden design. Be creative and “brainstorm” with your class for ideas. Consider creating a garden plan as a class project.

1. Break your class into groups of 4 and have each group develop and draw a diagram of a garden plan.
2. Discuss the advantages and disadvantages of each design. (If possible, invite others from the community who will be involved with the garden to participate in the discussion.)
3. Select the best design or designs to best fit your situation.
4. Draw this final plan on the board and have students copy it into their class notebook and/or into a Class Journal. Refer to the [Classroom Activity entitled *Keep a Journal*](#).

After you develop and select a final garden plan it is time to prepare your garden site!

d. Establish the Garden Site

In many cases a fence or natural hedge should be established before developing a traditional garden. This is because the outside perimeter of the garden can be an important component in reducing weeds and damage from pests. This area can be a barrier to stop intruding domestic and feral animals.

Implement the suggestions below to develop an effective garden perimeter. At minimum follow the first suggestion; each consecutive suggestion provides another level of protection, and following all five will provide the most protection.

1. Secure the perimeter by surrounding the garden with a fence.
2. Clear the area outside the fence about 2-5m wide. Keep the fence area weed free — both within and outside the fence — to avoid harboring pests and to eliminate any unwanted sources of weed seeds.
3. Plant insect-repelling and/or insecticidal plants such as marigolds, pyrethrum (*chrysanthemum*), or daisies. Plant directly adjacent to the fence to repel pests away from the garden.
4. Plant “defensive” plants such as sisal (*agave sisalana*) or African milkbush (*euphorbia tirucalli*) along the outer perimeter to repel animals. Sisal has sharp pointed puncturing leaves. The African milkbush has sticky and toxic latex (sap) which repels most animals.

- Between the outer defensive perimeter and the insect-repelling plants that you have planted along the fence plant low-maintenance plants that are adapted to poor soils, such as cassava or taro. These help eliminate weeds further and provide additional food.

Refer to the *Pocket Guide* for additional information on establishing a perimeter and/or animal-proof barrier.

School Garden Plan Example A

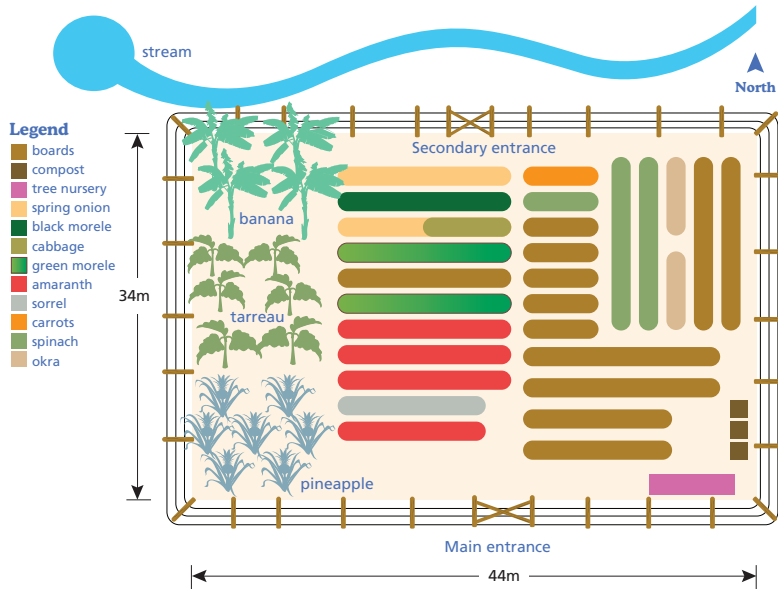

School Garden Plan Example B

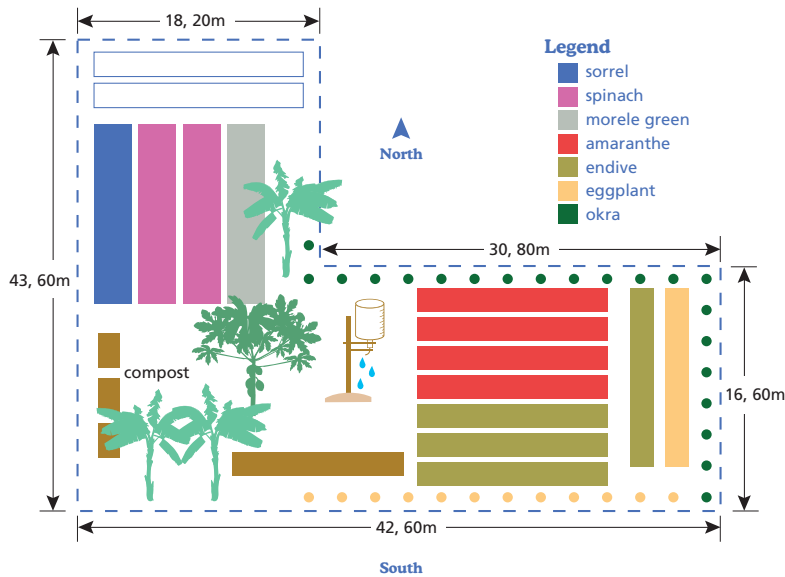

e. Prepare the Soil for a Garden

1. Measure out and mark off the area you will use.
2. Remove all large rocks and inorganic trash or debris: plastic, glass, aluminum, rubber, etc.
3. Remove unwanted plants and turn over the soil. Add green manure and compost.
4. Plant your garden. Ideally, plant your vegetables, fruits, and native plants in raised beds or trenched beds and add compost to the soil.

For more information see the section entitled *More Gardening Science*.

STEP 3 Planting the Garden

a. Types of Plants and Seeds

Methods for planting are as varied as the kinds of plants available. For example, small seeds such as carrots are "sprinkled" onto the soil, while large seeds like beans and corn are planted individually. Optimizing bed space is achieved by careful planting. In addition, planting times vary for different crops. Consult the *Pocket Guide* for additional planting information.

Plants come in a variety of forms, from leafy and non-woody (herbaceous) to woody vining, trailing, shrubby, and trees. Where and how various plants will be planted depends on their overall growth form and whether they have a fibrous or tap root system. Grasses and other plants with fibrous roots have numerous thin roots throughout the upper layer of soil for the most part, whereas carrots and other plants with taproots form a single main root which penetrates deeply into the soil.

Are Your Seeds Viable?

The variety and quality of your seeds, how they have been stored, and planting conditions are some of the factors that can influence the viability or germination rate of your seeds. Before you plant, test

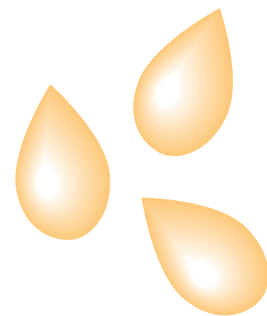

your seeds. When you know how viable your seeds are you can make the most of them by planting more if the germination rate is low or fewer if the rate is high. This well thought-out approach will help increase the productivity of your garden.

Use this simple seed test:

1. Select the seed type to be tested. If you have seeds from more than one source, be sure to label them, to keep them separate, and to conduct a separate test on each group. Place a minimum of 20 seeds in organized rows on a clean damp cloth. Cover the seed with another piece of clean cloth and roll up the cloth.

Place the rolled cloth in a shady place for 5-7 days. Then unroll the cloth and examine the seeds; most viable seeds will have germinated within this period of time, and will display sprouts as is illustrated here.

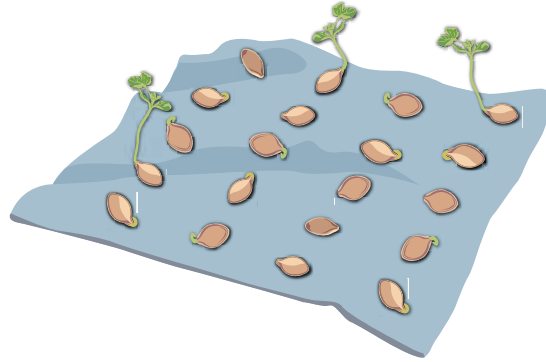

2. Count the number of seeds that have germinated and divide that number by the number you first tested. This is your germination rate. If the germination rate (GR) is less than 85%, you should plant extra seeds. The lower the GR, the more (extra) seeds you must plant to ensure that the beds are fully planted. For example, if you want four squash plants but the germination rate was only 70%, you will need to plant enough seeds for five or six plants. This calculation is illustrated below.

$$\frac{\text{Number of Seeds Germinated}}{\text{Number of Seeds Planted}} \times 100 = \text{Percentage of Germination Rate}$$

$$\frac{14 \text{ Seeds Germinated}}{20 \text{ Seeds Planted}} \times 100 = 70\% \text{ Germination Rate}$$





Share the News!

Inform persons who could have an interest in using the area, or who may pass through the area with vehicles, animals, etc. about the garden site; this will eliminate the possibility of damage to the site or potential conflicts of interest.

b. Planting

Create a garden map on paper; this "Master Garden Plan" will help you manage your garden. Use the Master Garden Plan to show what has been planted where; revise and update it as you add plants later. Make copies for all who are involved and distribute revised versions when necessary. Remember to update your Master Garden Plan(s) and records each time you plant and harvest so that you can be sure to rotate your crops.

"Label" your garden plants. The labels help students and parents learn what the different plants look like and help you remember what you planted. Be sure to follow the planting map from the Master Garden Plan.

- Mark off and label the rows and different things to be planted; use small signs with the name and drawing of each plant.
- Attach the signs to a stick (about 40 cm. high); bamboo strips are excellent for this.
- Place the stick at the end of each row or next to the plant.

Plant your seeds or transplant your seedlings. Some plants you will plant as seeds, others as seedlings. For example, native plants (e.g. papaya) can be gathered elsewhere and transplanted as seedlings, or their seeds may be gathered and planted.

For more on propagating and transplanting seedlings, refer to the section entitled: *More Gardening Science*.

Here are some general planting guidelines.

- Most seeds should be planted in the soil twice the depth of the seed size. (Example: Plant a 1 ¼ cm. squash seed 2 ½ cm. deep.)

Planting Depth

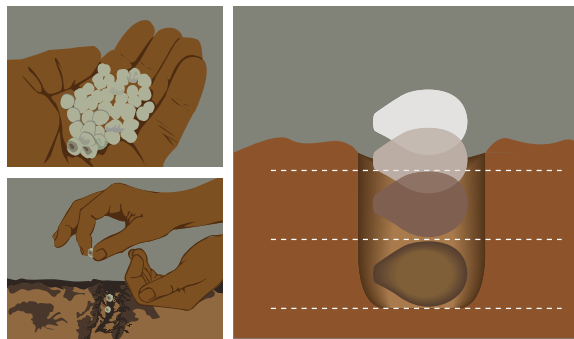

Planting Depth Some Examples			
Plant	Length of Roots	Sunlight	Moisture
Carrot	medium/deep	partial sun	keep soil moist below 4 cm.
Onion	shallow	bright	keep top soil moist
Pepper (green and red)	medium	bright	keep soil moist below 2 cm.

- Spacing. How large will the plant be when it is full grown? The answer should dictate plant spacing. Space the plants about one hand width apart. The foliage of a plant above ground and the roots underground both spread about the same amount.

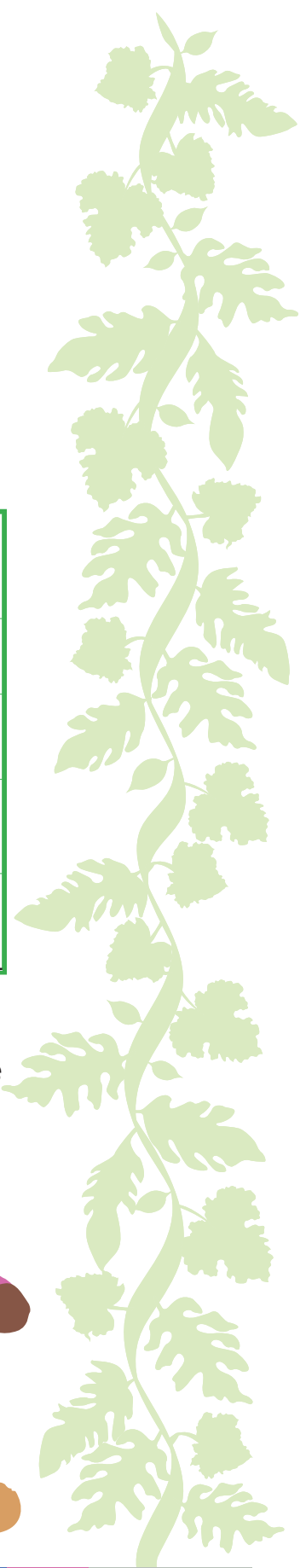
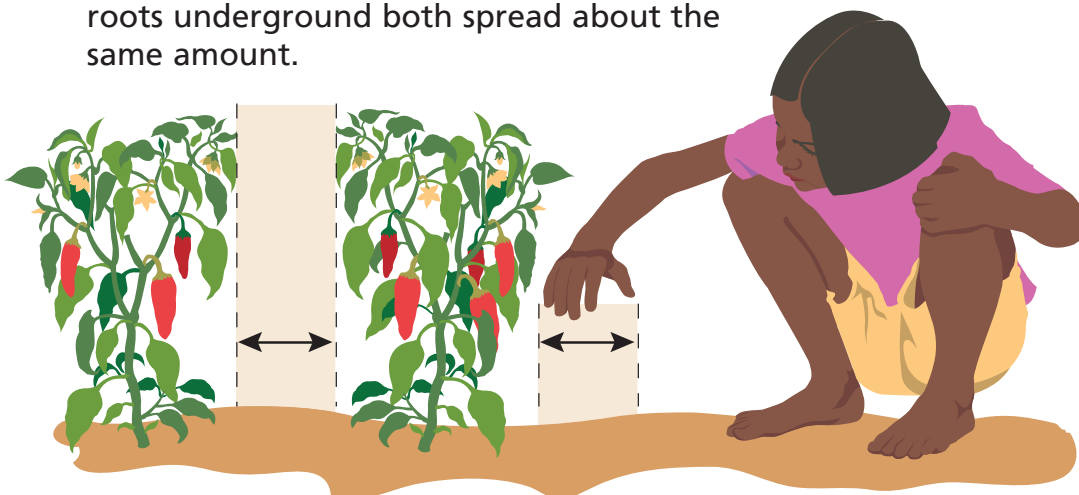

- Wide plantings with groupings of plants produce higher yields and conserve nutrients, water and soil. For example, plants such as spinach and green beans grow better in a wide row of about 6 plants across instead of in a single row of the same number of plants.

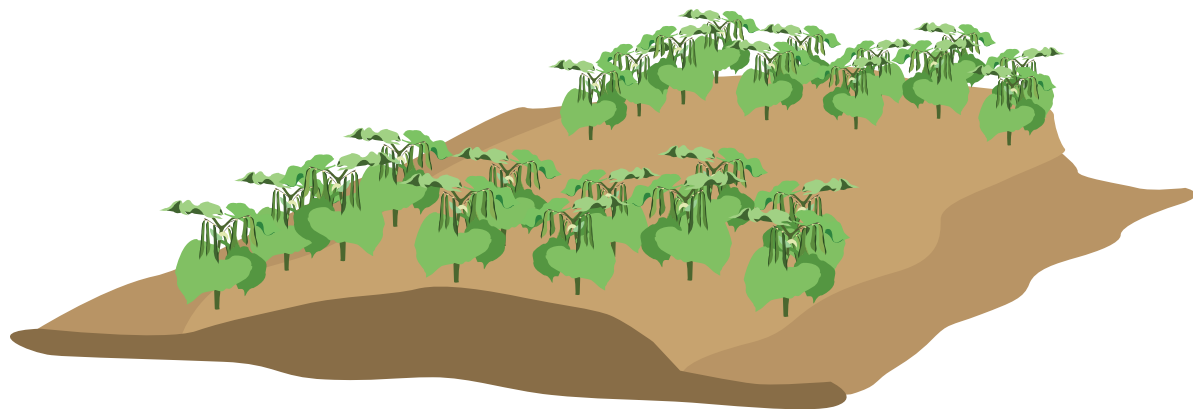

- Companion planting. When deciding what plants to put close together, consider the varied root depths. Varied root levels are preferable because each plant can use the nutrients at different levels in the soil.
- Some plants like a lot of sunlight, while others grow better with more shade. Plant your garden so that each plant has favorable growing conditions.
- Water seeds and plants thoroughly as soon as they are planted.

The *Pocket Guide* provides more guidelines to help you decide when to plant, and includes some specific information for the various vegetable crops you may plant in your gardens. Also, seek help and advice from people in the community who have been growing plants like those you will be cultivating in your garden.

As your gardening skills and knowledge improve, you may want to try some additional gardening techniques such as companion gardening and saving seeds. Both are described later in this Manual.

STEP 4

Tending the Garden

Planting the right seeds or plants in the right place is only one part of the formula for good food production. Remember that the garden is an ecosystem. And like all ecosystems, a sustainable garden will include a multitude of organisms. Our task is to control our ecosystem by retaining beneficial organisms and omitting unwanted ones. Simply put, this means taking good care of your garden by composting, managing unwanted plants, watching for pests and disease, and watering.

Like all ecosystems, a sustainable garden will include a multitude of organisms.

We must monitor what non-living elements are being removed or added. For example, if the garden is on a steep slope, do you expect all of the nutrients in the soil to remain in the garden or to leach downhill? What happens to your garden if you use synthetic fertilizers or insecticides? This section addresses these issues.

a. Thin and Transplant Young Plants as Necessary

Some plants – such as carrots or beetroot – should be thinned out after they sprout. Thinning improves yield because it helps the remaining plants grow larger and stronger. Other plants – such as tomatoes – may be transplanted (after they grow a few centimeters) from a more protected area to a place that gives them more room for vining and growing.

There are two ways to thin plants.

1. Thin the seeds themselves before planting.
"Pre-thinning" works well for small seeds such as carrots and lettuce. Mix 1 part seeds to 4 parts sterile sand. Sprinkle or scatter onto the soil. (Sand can be sterilized easily by heating it in a pan or tin over a fire for about an hour.) This method produces the most plants from the fewest seeds, requires less labor for thinning, and makes the most of scarce seeds.
2. Remove excess plants after they have sprouted.
Spread seed thinly over soil. After plants germinate, remove many of the seedlings so remaining plants have ample space and resources.



b. Incorporate Compost to Provide Important Plant Nutrients

In order to grow healthy and complete their life cycle, plants need essential nutrients:

- for green growth and protein in the plant,
- for plant reproduction: flowers, fruits, and seeds,
- for root growth, water uptake, and disease resistance.

Compost is an organic fertilizer that provides these essential plant nutrients. Compost provides a free and effective fertilizer for your plants and soil. Add compost to your garden when you plant a new crop; do so by working it into the soil with roughly one part compost to three parts soil. While a plant is growing, add compost to the base of it every several days so the soil depth remains about the same.

More information on compost and how to make it is provided in the section entitled *More Gardening Science*.

Compost fertilizer works best when you use a small amount frequently, rather than a lot at one time.

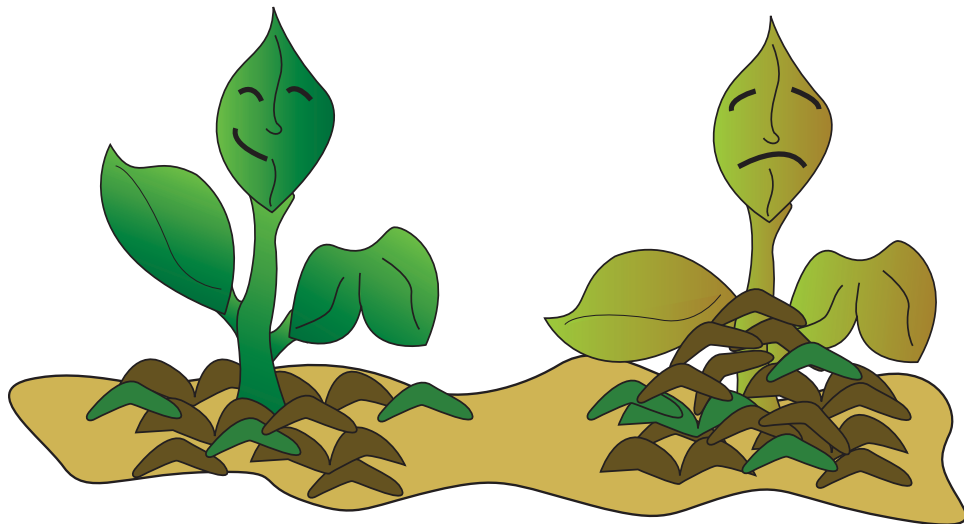

c. Apply Mulch

Mulch is composed of coarse plant materials such as leaves, fibers, wood chips, etc. that can be placed directly into the garden at the base of plants, or used to create pathways and borders. Keep adding mulch to your garden so that it is about 8 cm. deep. Continually adding mulch has many benefits:

- Conserves water – protects the soil from sun and wind evaporation.
- Controls weeds – blocks sunlight to reduce weed growth.
- Insulates soil – keeps soil cooler in hot temperatures.
- Reduces erosion – slows water flow.
- Improves soil structure – reduces compaction of soil, increases biological activity, and adds nutrients.

Larger objects can also be used for compost. Dead logs will rot in the garden and provide mulch. Trees decompose quickly in the tropics and can act as markers or barriers in the garden.

More information on mulch is in the section on *More Gardening Science*.





d. Water the Garden

Since water is often a limiting factor for gardening during the dry season, wise use of all available water is essential.

Plants need about 3 cm. of rain each week. Set out a container to measure the rain. If you do not have 3 cm. of rain in about 7 days, you will need to water the garden.

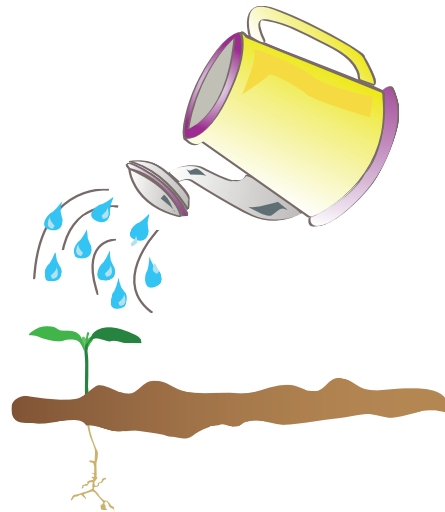

The best time to water is in the morning or early afternoon so that the leaves can dry before nightfall, thereby reducing the chance of disease from mildew. Tomatoes do not do well if their leaves get wet; when watering by hand, water deeply at the base of the tomato plant, thereby minimizing water on the leaves.

Keep in mind that plants have different root depths that affect how much water they need. Plants with shallow roots should have moist topsoil and, therefore may need water more often than plants with deeper roots. Plants with medium-length roots can have dry topsoil, but the soil should be kept moist approximately 2 cm. below the surface. Plants with deep roots can have dry topsoil but should be kept moist approximately 4 cm. below the soil.

The *Pocket Guide* provides information about root depth for some vegetables.



e. Rotate Crops

Rotate crops from season to season. It helps to do so because different plants use and/or return different nutrients to the soil. Also, plants that are related tend to have the same pest and disease problems. In sum, if you rotate your crops pests will be less likely to eat them, and diseases may not establish or spread as easily.

In addition, when you rotate crops you lessen the depletion of nutrients from the soil and actually help to rejuvenate it.

This illustration shows how to rotate plants. Note the 5 categories of plant families.

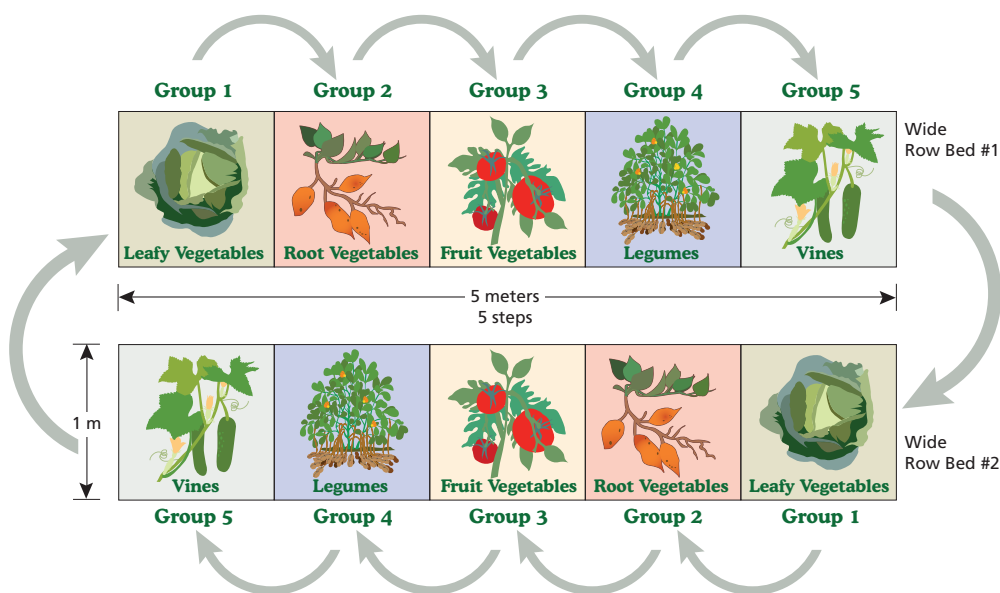

For crop rotation, it is important to know that the Leafy Vegetables and Fruit Vegetables families are the most likely to attract pests or become diseased, and they deplete more nutrients from the soil than plants in other plant families. Therefore, do not plant leafy vegetables or fruit vegetables in the same place successively.

For example: first plant and harvest a crop of tomatoes and peppers. Next, plant peanuts in that same soil. After the peanuts are harvested the soil will be replenished. Next plant vegetables from another family such as vines or leafy vegetables.

Leafy Vegetables

Cabbage, cauliflower, broccoli and amaranth. Crops in this family are heavy feeders. Provide these plants with plenty of animal dung and compost fertilizer for optimum growth.

**A diverse garden...
is a healthier garden
and a more
interesting garden**

Root Vegetables

Carrot, beet, sweet potato, and onion. Do not apply fresh dung near the planting time for these crops, as this may lead to forking of roots. Similarly, if too much nitrogen fertilizer is applied, the crops may produce many leaves but fewer roots and tubers. As mentioned above, plant these vegetables in different places from year to year to prevent disease.



Fruit Vegetables

Tomato, potato, green and red pepper, eggplant, lettuce and Swiss chard. These crops are grouped together because the first four vegetables listed must not be grown one right after the other. They are all in the same family. Lettuce and Swiss chard are really leafy crops, but are placed in this group for rotation purposes; all in this group can harbor similar pests in the soil.



Legumes

Bush bean, pole bean, peanut and pea. Legumes are not very heavy feeders so they require less fertilizer.

Like peas and peanuts, legumes replenish the soil by fixing nitrogen in the soil. As such, they are particularly valuable for crop rotation, because nitrogen is generally the most common limiting factor nutrient for plant growth.



Vines

Cucumber, pumpkin, squash, melon, watermelon. These vine crops are all part of the *Cucurbits* family and are subject to relatively few soil-borne diseases.

f. Manage Weeds, Pests and Diseases

The garden is an ecosystem, and a sustainable garden generally does not incorporate the use of synthetic fertilizers or pesticides. These chemicals are expensive and usually have side effects which interfere with natural, ongoing ecological processes. For example, over-use of artificial fertilizer keeps beneficial soil bacteria and fungi from growing and helping the soil, thus leading to long-term soil infertility.

Weeds

Weeds compete with garden plants for water, nutrients, and sunlight, and therefore should be removed as soon as possible. When weeding, be sure to remove the roots along with the plant. Many plants will sprout again if a portion of the plant or root is left in the soil. The best way to suppress weed growth in your garden is to cover areas of exposed soil with mulch. Also, remove weeds from areas next to your garden so that fewer weed seeds will blow into or be carried into your garden.

Pests

- To control pests, have a variety of plants. Diversity discourages dissemination of crop-pests by insects because they must crawl/hop/fly to find the particular plant they are looking for.
- Plants with a fragrance – such as onions, garlic, marigolds, cosmos, and licorice basil – deter insects because they can mask the fragrance of other plants and at the same time repel harmful insects.
- Closely monitor your garden for pests. If any damage is found, try to determine the type of pest causing the damage. In many cases, if the pests are discovered early enough, they and their eggs can be removed by hand.
- If the infestation is beyond simply removing the pests by hand, you may need to spray a natural insecticide. *Refer to [Natural Pesticides](#) within the section on [More Gardening Science](#) for directions on how to prepare this.*
- Other approaches to pest management include nature itself. If you let chickens run through the garden, they may eat a few tomatoes but they will also eat a large number of pests and deposit a little animal dung, a natural fertilizer.



Diseases

Plant diseases caused by viruses, bacteria, and fungi are more difficult to control. Most microbial plant diseases take advantage of already diseased or over-stressed plants.

- Monoculture (growing only one type of plant), poor soil, incorrect plant culture, improper watering (too little or too much), or poor insect pest management increases the likelihood of plants becoming diseased.
- Avoid overhead watering of leaves late in the day or at night, as some plants are more likely to become infected by fungal diseases such as mildew.
- If diseases are discovered early enough, try to remove the infected portions as soon as possible; after such trimming be sure to thoroughly wash your hands (and any trimming equipment) before you touch healthy plants.
- Burn or discard diseased portions and do so as far as possible from your garden. If much of the plant is diseased, it is probably best to remove the entire plant and dispose of it.

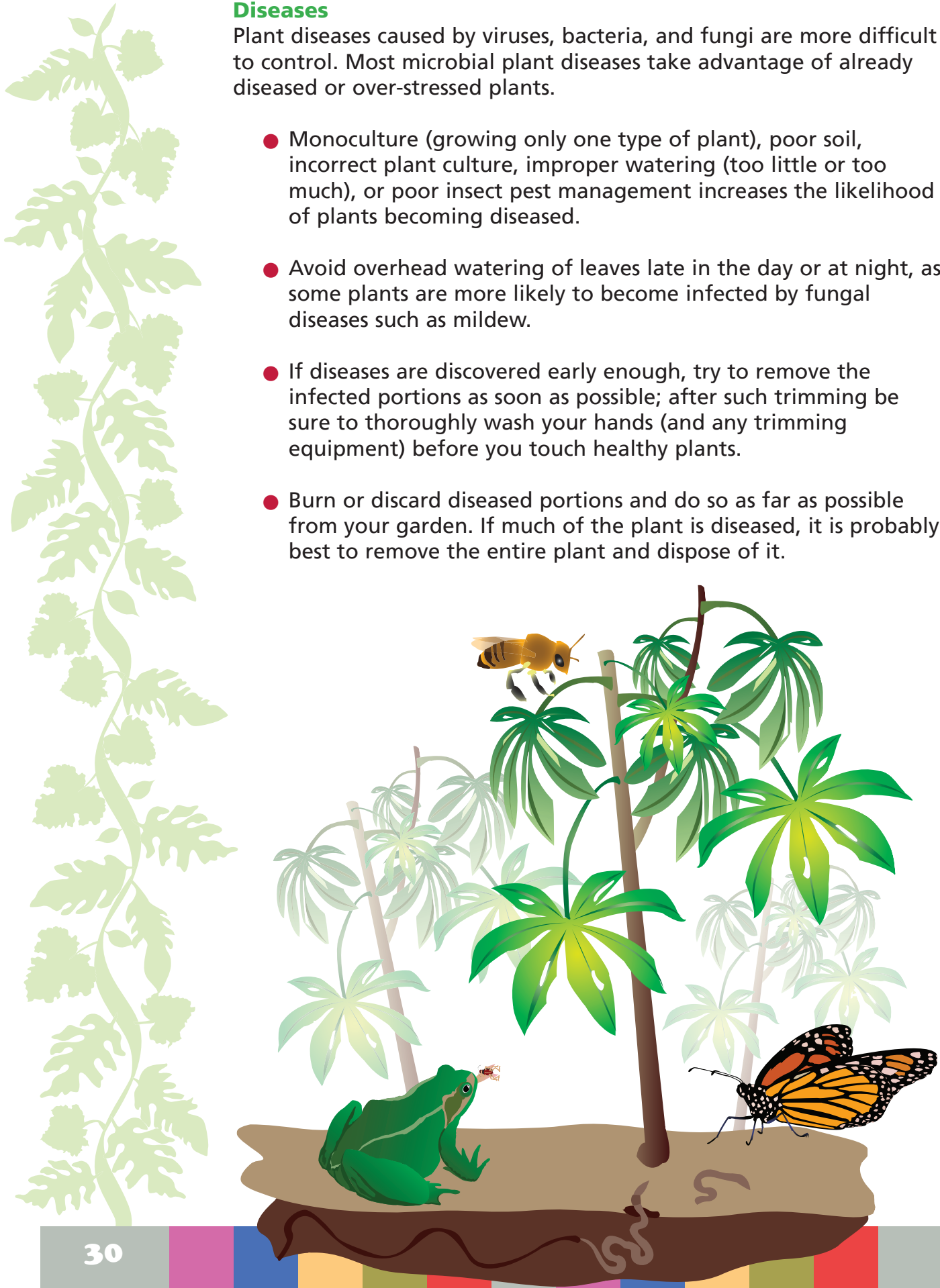

Helpful and Harmful Animals

While chickens can be beneficial to your garden (as mentioned above), animals such as goats may harm your garden by eating the plants and vegetables. It is important to keep these animals out of the garden. To do so, you can make a living hedge or a fence of living plants. This natural barrier is an easy way to keep unwanted animals away while creating fertilizer at the same time.

Some plants work especially well in deterring animals. For example, if you plant Minguegue fig closely together you can create a living wall. Meanwhile, you can eat the figs and use the leaves as mulch and composting materials, and the vine creates a thicket that animals cannot easily penetrate. Adding an additional barrier of lemongrass outside of the Minguegue will create yet another layer to your border. Besides discouraging pests, lemongrass can be used as a food seasoning, a tea beverage, for mulch, and in compost.

Other creatures of all sizes contribute to the richness of your garden soil. For example, earthworms aerate the soil and increase the quality of the soil. Chickens and frogs eat unwanted pests and deposit fertilizer in their dung. Bacteria that is naturally present in the soil helps mulch and dead plants decompose into soil. These various forms of life help to create a more diverse and balanced garden system.

g. Keep Your Soil Fertile

Keeping your soil fertile is just as important as tending your garden. As mentioned earlier, you should prepare your soil properly before you plant your garden; do so by adding a natural fertilizer (see page 68), along with compost. During the growing season you need to take the same steps to increase the life span and productivity of your garden:

- apply compost,
- apply mulch, and
- rotate crops.

Soil, like the garden, is far more than the sum of its parts. The soil is a complex, dynamic, living system; it is a repository, or bank, for the needs of the plant's roots. These include a constant supply of water and air, along with numerous minerals such as nitrogen, iron, magnesium, and calcium. Because roots cannot photosynthesize below ground, they must respire (explained on page 50). Most plants with roots submerged in water will eventually die.

Soil, like the garden, is far more than the sum of its parts.



Soil is composed of materials from its parent material. This includes local rocks and accumulated dead plant and animal materials, combined with the organisms living within these materials. Hundreds of species of various organisms exist in just a spoonful of soil – from microscopic bacteria, fungi, and nematodes, to larger invertebrates such as insects, spiders, earthworms, and so on. Soil fertility is maintained by the constant weathering of inorganic materials combined with the addition of new organic material (compost) and the decomposition of these complex materials back into smaller, useable forms available for plants.

Plants do best when they have a continual, long-term source of nutrients and water. When a crop is finished and debris is cleaned out, it is time to add organic matter to your garden soil. Use 2-4 cm. of compost or livestock dung; spread it over the entire garden area, and turn it into the top few centimeters of soil.

Garden Challenges and Garden Solutions	
Challenges	Solution
No water source nearby.	<ul style="list-style-type: none">● Dig a well. You may need to go very deep.● Have students bring water from home.● Recycle gray water
Wild animals get into garden.	<ul style="list-style-type: none">● Plant sisal barrier outside fence.
No seeds provided by garden sponsor.	<ul style="list-style-type: none">● Learn how to save seeds.● Use funds from the sale of garden produce to buy seeds.
Materials wear out. (For example, watering cans, hoes.)	<ul style="list-style-type: none">● Have students bring hoes or buckets from home for one day/week when it is their turn to work in the garden.● Use funds from the sale of garden produce to buy new materials.



Garden Challenges and Garden Solutions (Continued)

Challenges	Solution
Garden requires care during school holidays.	<ul style="list-style-type: none"> ● Schedule students and parents to come to school to tend the garden. ● Schedule older students to supervise younger students who are tending the garden. ● Time planting so few or no plants need tending during holidays. ● Use funds from the sale of garden produce to pay someone to care for the garden during holidays (or pay them with produce).
Garden is too large to manage weeds and watering.	<ul style="list-style-type: none"> ● Alternate planting half of the garden at a time. Plant one half with vegetables. Plant the other half with a legume such as Angolan peas (<i>cajanus indicus</i>) for green manure. You will be enriching the soil so it is ready for the next planting cycle. Then plant vegetables in the second half and legumes in the first half.
Compost supply is too meager.	<ul style="list-style-type: none"> ● Create new compost piles. ● Have students bring organic materials from home for the pits.
Garden produce is stolen.	<ul style="list-style-type: none"> ● Build theft-proof fence with a door that locks. ● Increase security by involving the community in the garden. ● Relocate garden to more secure site.
Parents or students are not motivated to help.	<ul style="list-style-type: none"> ● Choose committee members who know how to handle people as well as plants. ● Give praise, rewards, prizes and other incentives for children, teachers, helpers and committee members. ● Publicize success and make garden activities visible to the public and the whole community. ● Create pride, status, achievement and pleasure in the garden. ● Have competition between the classes.
Students do not want to eat new foods from the garden.	<ul style="list-style-type: none"> ● Give lessons about the new foods. ● Invite parents to a workshop on how to prepare the new foods. ● Have the cooks mix the new foods with rice, cassava, or other familiar food.

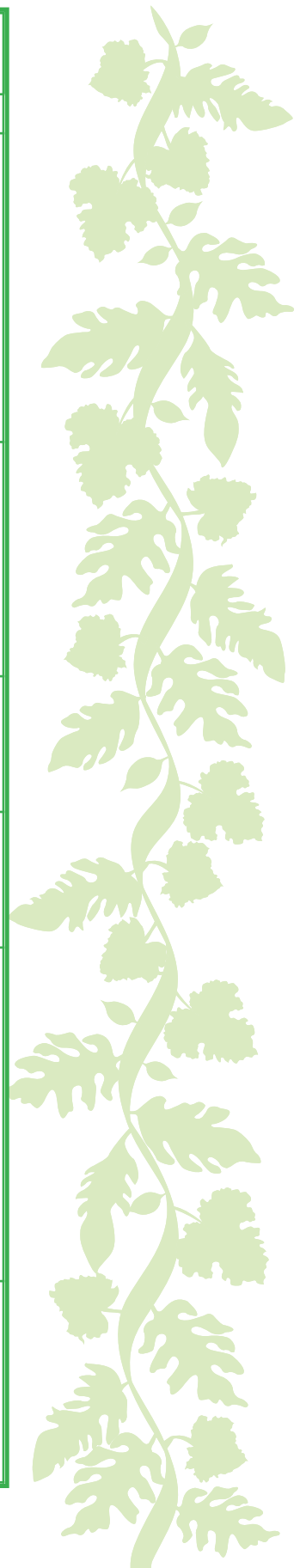

STEP 5: Harvesting, Preparing, and Eating the Food

Some plants will need to be harvested frequently and others just once. Use the *Pocket Guide* for an idea of when you should harvest each vegetable or fruit. Fruits are ready to harvest when they can be removed easily from the plant. Fruits that are harvested before they are fully ripe are less tasty and will have fewer nutrients. Explain to the students why we pick the crops only after they are ripe.

Days to Harvest and Method Some Examples		
Plant	Days to Harvest	Harvest Method
Beans (bush)	45-60 days	Harvest frequently to encourage new growth.
Spinach	45-60 days	Pick when larger leaves are 15-20cm. long. Harvest often so spinach continues to produce new leaves.
Sweet potato	100-130 days	Does not need water in the last weeks before harvest. Dig small amount to determine if ready to harvest.

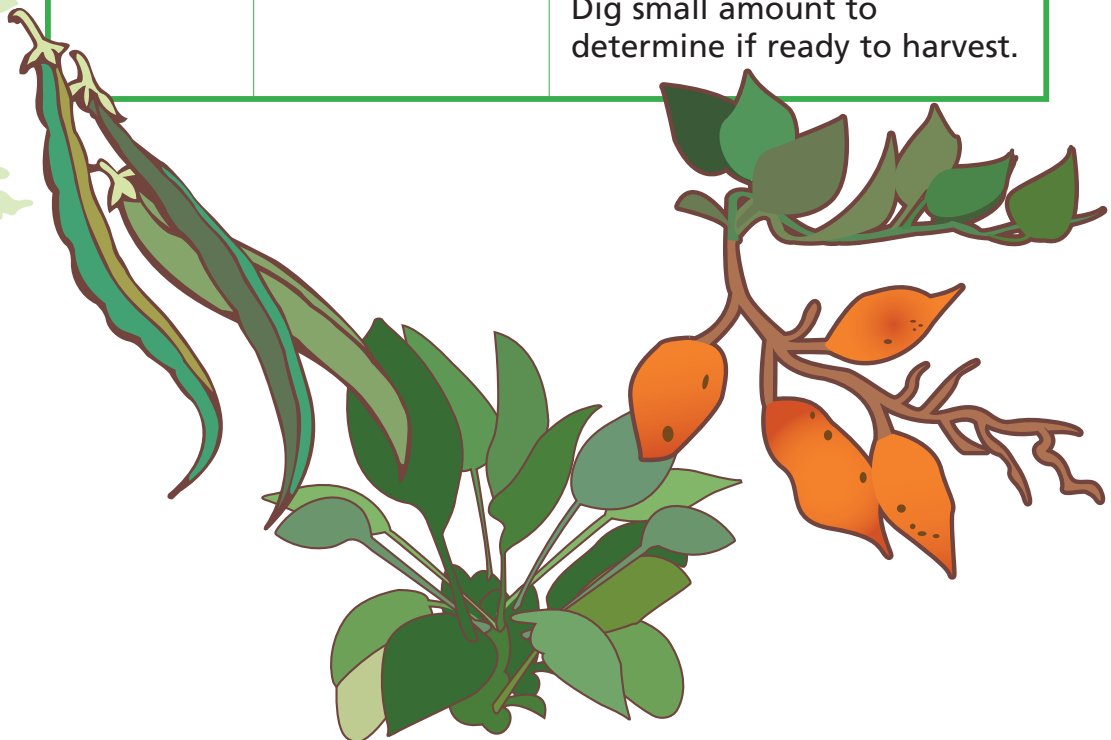

a. What to do With Garden Produce

The students need to learn how to harvest the garden vegetables, and should be able to observe the way they are prepared for eating. Students miss an important part of the garden and growing cycle lesson when they are not asked to help harvest the produce or to take it directly to the market. Further, Garden Committee members or teachers are missing the point if they take these steps on their own without the students. Instead, help the students connect what they do in planting and tending the garden to good eating and nutrition.

As mentioned earlier in this Manual, the main purposes of the school garden are to do the following:

1. Produce food for a school feeding program.
2. Provide a laboratory to supplement the standard school curriculum.
3. Contribute to the intellectual, psychological, and physical development of the students.
4. Transfer skills and knowledge from the school garden to home and community.

Use these purposes as your guide when determining what to do with the produce from the garden. As a teacher you actively encourage students to come to school (and to learn about gardening). Meanwhile, you should encourage the support and involvement of parents and the wider community.





In addition to these guiding purposes, there is no reason why a well-planned and managed garden cannot also serve as a source of income for the school. This serves as another purpose for the school garden:

- Produce income generating plants.

No single plant is best for providing income, simply because of the widely varying local situations. It is best to first plan for the school's needs, and then to plant and perfect the cultivation of plants that will best provide income.

Explore the local market and learn from parents and community members just which vegetables and fruits are most desired and which are limited in supply; these usually fetch the highest prices. Among these, determine if you have the area within your garden or school grounds, the expertise, the labor, and the resources to develop one or more income generating crop.

The following table offers some recommendations for the use of produce, along with potential advantages and disadvantages of each. You can choose one or two approaches or a combination.

Keep in mind that if garden produce is sold, the profit should go towards the greater good of the school, garden or students. It is not appropriate to use the earnings for parties, for bonuses to the Director, or for personal gain.

Ways to use Produce and the Advantages/Disadvantages of Each		
Use of produce	Advantages	Disadvantages
Use in the school food program	<ul style="list-style-type: none">● Students will eat more nutritious and tasty meals, be exposed to new foods, and see a connection between their work and the vegetables.● Serves as an example for home gardens.	<ul style="list-style-type: none">● May not be enough food to serve all students.● Produce may not be ready for consumption on a day when school is in session.



**Ways to use Produce
and the Advantages/Disadvantages of Each (Continued)**

Use of produce	Advantages	Disadvantages
* Sell in the village market.	<ul style="list-style-type: none"> ● Can earn money for the school for more seeds, fees, volunteer teachers, supplies, sports equipment, academic prizes, building repair, supplies and foods for the feeding program, etc. ● Can promote the school garden to the wider community. 	<ul style="list-style-type: none"> ● No nutritional benefit for students. ● Students see the garden as a way to earn money rather than to eat better. ● Students may not be exposed to new foods. ● Students may not learn how to prepare and use the produce. ● Students may not understand how fresh produce can improve their health.
** Sell to parents.	<ul style="list-style-type: none"> ● Parents are aware of the benefits of the school garden. ● Can earn money for the school as listed above. 	<ul style="list-style-type: none"> ● Same as above
Give as payment to people who work in the garden.	<ul style="list-style-type: none"> ● Can help maintain garden when students are not in school. 	<ul style="list-style-type: none"> ● No nutritional benefit for students.

* If you sell in the market, be sure to make a sign or to tell buyers that the vegetables came from the school garden. This will help build community awareness of and support for the school garden.

**Have the students tell parents when the produce will be available so more parents have an opportunity to purchase.



b. Eat a Variety of Foods

We cannot live on fruits and vegetables alone. We need grains and proteins to provide us with additional nutrients. Section C which follows details the major nutritional benefits of each of the foods in the garden.



Because many households around the world are food insecure, it may be difficult for students to eat a variety of good food. The school garden is designed to provide foods that are healthy and to provide many of the nutrients the students need. Understanding the importance of different foods may motivate students and parents to strive for variety in their diets.

1. Different plants provide different benefits, and no single food has all the nutrients we need. The chart at right shows the benefits of three common foods from the garden.
2. Some nutrients stay in our bodies for several days; others we need daily. We store the vitamin A from sweet potatoes for several days because it is fat soluble. Conversely, we need vitamin C every day because it is water soluble and washes out of our bodies quickly in our urine. Vitamin C is found in many fruits and in tomatoes.
3. Some nutrients need to work with another nutrient or partner in order to reach their full potential. For example, we cannot absorb calcium unless we also take in vitamin D. In turn, vitamin D is present in eggs and can also be absorbed directly from the sun on our skin. The vitamin C in tomatoes helps us absorb the iron in spinach.
4. Good nutrition can help fight malaria and other diseases. Foods rich in vitamin A work best in combination with foods rich in zinc. This pairing is especially beneficial and easy to achieve. For example, combine spinach, carrots, and/or sweet potatoes (foods high in vitamin A) with green beans and/or cabbage (foods rich in zinc).

Common Vegetables and their Health Benefits Some Examples		
Plant	Vitamin	Health Benefits
Cabbage	<ul style="list-style-type: none"> ● vitamins A, C ● zinc 	<ul style="list-style-type: none"> ● helps heal cuts and wounds; protects from infection; boosts the immune system; keeps skin and gums healthy. ● helps absorb iron. ● helps eyes see at night. ● fights malaria and other diseases.
Tomato	<ul style="list-style-type: none"> ● vitamins A, C 	<ul style="list-style-type: none"> ● helps heal cuts and wounds; protects from infection; boosts the immune system; keeps skin and gums healthy. ● helps absorb iron. ● helps eyes see at night.
Yellow/orange vegetable such as sweet potato	<ul style="list-style-type: none"> ● vitamin A ● iron 	<ul style="list-style-type: none"> ● builds and maintains healthy eyes, skin, bones. ● iron builds blood cells to fight anemia.

Eat Well!

Food is important not only to relieve hunger. Food is also important to help boys and girls grow up strong and healthy. Eating the right foods gives us energy to do our work and to play.

Children who eat breakfast and eat well can concentrate and do better in school. There are things one can do in harvesting, preparing and eating food that can help us make the best use of its benefits.



c. Eat Nutritional Foods

The fruits and vegetables grown in the school garden help our bodies in many ways. Here is an overview of their nutritional benefits.

Nutritional Benefits of Common Fruits and Vegetables	
Amaranth	Good source of vitamin A, B, C, and calcium, iron.
Banana	High in potassium and energy. Easily digested (good for infants and elderly persons). Small amounts of vitamin A and C.
Cabbage	Vitamin A, C, zinc and fiber.
Carrot	Excellent source of vitamin A.
Cassava	High in vitamin C. Good source of fiber and some energy.
Citrus	Excellent source of vitamin C.
Collards	Excellent source of vitamin A and C, iron and calcium. Some vitamin B and K, folate and potassium.
Corn	Energy, potassium, fiber, vitamin B.
Cucumber	High in potassium and fiber. Some vitamin A, B, C.
Eggplant	High in potassium.
Endive	Vitamin A, C, K, iron, calcium, potassium, folate.
Green Bean (French Bean)	High in fiber, iron, zinc and potassium.
Gumbo	Vitamin C, iron, calcium and potassium.
Mango	Excellent source of vitamin A and C, and potassium.

Nutritional Benefits of Common Fruits and Vegetables (Continued)	
Onion	Vitamin C and potassium.
Papaya	Excellent source of vitamin C. High in vitamin A. Contains papain, an enzyme which aids digestion.
Peanut	Excellent source of protein, fat, iron, vitamin B.
Pepper (green or red)	Excellent source of vitamin A. High in vitamin C. Mostly useful for adding flavor.
Pineapple	High in vitamin C.
Plantain	High in vitamin A and C. Some iron.
Pumpkin	High in vitamin A and energy.
Safu	Excellent source of plant oils and protein. Aids in the absorption of some vitamins, especially vitamin A.
Sorrel	Some vitamins, minerals and fiber.
Spinach	Excellent source of vitamin A. High in many other vitamins and nutrients, including vitamin B, C, K, iron, calcium, folate and potassium.
Sweet Potato	Excellent source of vitamin A and C. Raw leaves are rich in iron, vitamin A and C, and energy.
Tomato	High in vitamin A and C, and lycopene.
Yam	Good source of vitamin C.

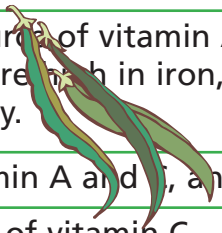

d. Cook Foods for Maximum Nutrition

Most foods are healthier when they are eaten as directly from the garden as possible. Vitamins are very sensitive to heat, water and oxygen and are easily destroyed when we cook, bake, or dry the fruits and vegetables that contain them. For example, when we boil greens, many of the vitamins move from the greens to the water. When we cook tomatoes, some of the vitamin C is destroyed. Drying sweet potatoes destroys the vitamin A that benefit our eyes. Therefore, it is best to cook fruits and vegetables with as little water – and in as short a time – as possible. That way, when you pour off the excess water, you are pouring out fewer nutrients. Better yet, do not waste the water and instead use it as a base for soup.

A food safety reminder:

Everyone is vulnerable to a variety of food-related illnesses. It is always helpful to remind everyone of this important safety tip:

Wash your hands!

Remind everyone of this important safety tip!

Everyone is vulnerable to a variety of food-related illnesses, these illnesses are spread easily by dirty hands.

Wash hands before preparing food!

Wash hands after using the toilet!

These steps are easy and effective ways to prevent disease.

Children in particular often suffer from diarrheal diseases that could be prevented simply by washing their hands.



C. More Gardening Science

As your school garden becomes more productive, you may want to try some of the following gardening variations.

1. Alternative Planting Methods

a. Companion Gardening

This method mixes plants together to maximize space, provide natural pest control, and promote favorable growing conditions for each plant in the grouping.



To maximize yields, interplant crops that have varied root levels. For example, onions, eggplant and peppers each have roots which seek nutrients at different depths in the soil. Each plant also promotes the proper biological functions to restore the nutrients that the other companion plants use.

Plant marigolds among your vegetable plants. Each plant emits a fragrance which deters unwanted insects and at the same time attracts beneficial insects.

Some plants should not be planted together. They may stunt each other's growth, attract harmful insects, or release chemicals that suppress growth.

- Do not plant corn with tomatoes.
- Do not plant potatoes near squash or peas.
- Do not plant peas or beans next to onions.



An Example of Companion Gardening

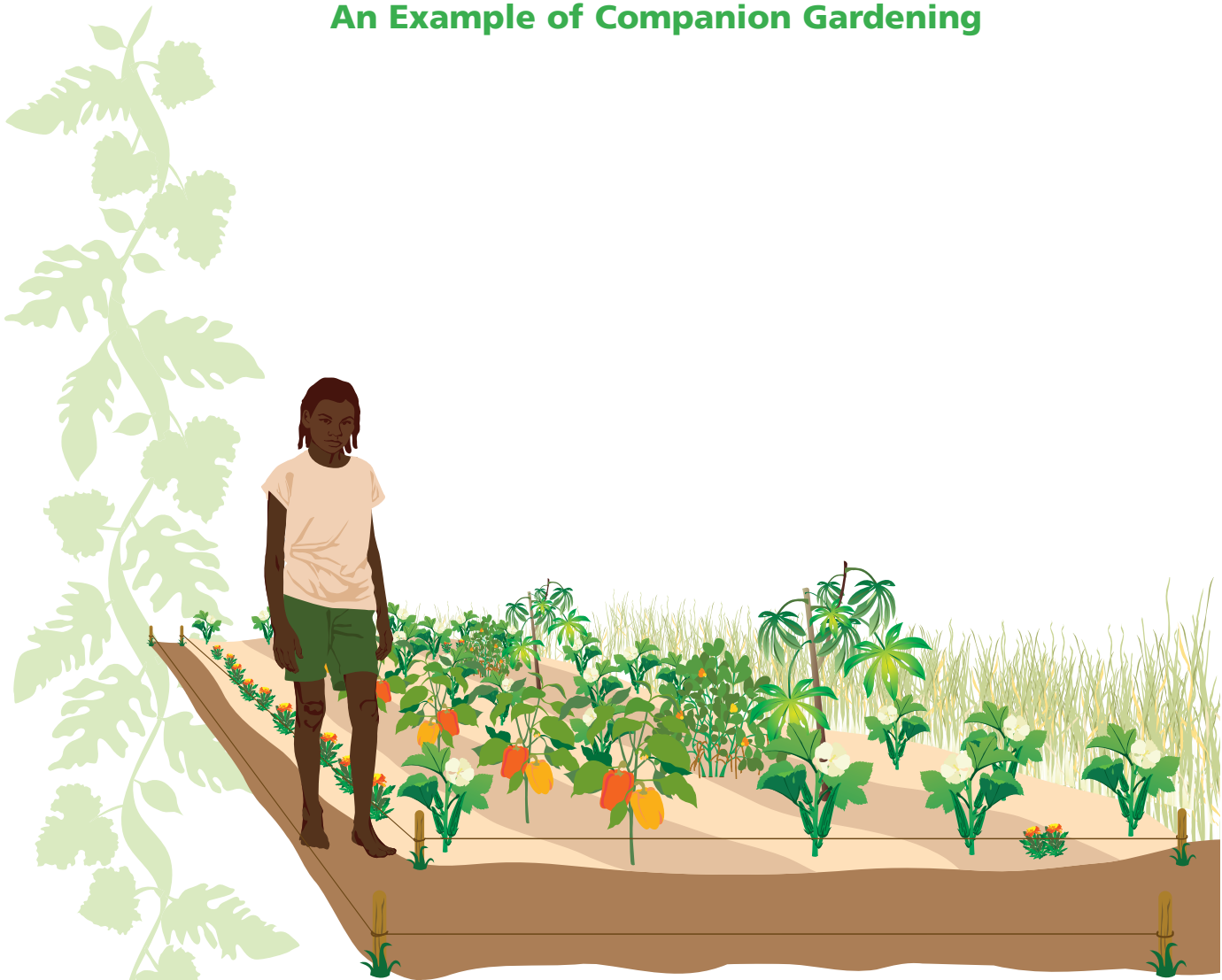

Keep trying!

It takes a while to establish a school garden. The first three years can be the most challenging. Use this time to observe and understand the plants and the garden and how you can integrate the garden into your school more thoroughly.

During this time, think of every failure as a success. Every time something fails we learn from it and improve our knowledge and experience. There is usually more than one solution to a challenge. Keep trying!

b. Gardening with Terraces

Does the ground slope, or have a lot of uneven terrain? A level garden is not necessary, but it sure makes gardening easier.

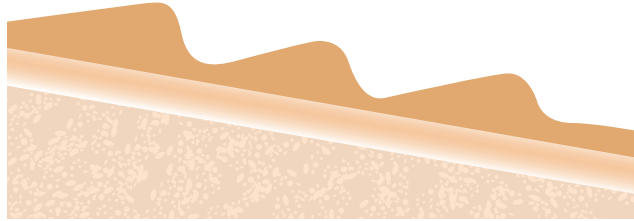

If the site is on a slope, severe soil erosion problems can be caused by heavy rains, which can wash soil and valuable nutrients down to lower areas. Through time the garden will lose valuable topsoil, along with the compost and animal dung that you have worked so hard to add to build your soil.

You do not want all your hard work to wash away over time! This can happen slowly or swiftly. If the site is sloped you can build simple terraces that will prevent runoff, thereby preventing soil erosion and saving your valuable topsoil.

c. Gardening with Raised Beds

Raised beds are simply regular garden beds that are raised above ground level. The beds can range from only a few centimeters high to nearly a meter high. There are advantages and disadvantages to gardening with raised beds.

Advantages of a defined bed above the soil level (or directly upon rock, when no soil is present)

- easier to add compost and mulch
- easier weeding and tending
- reduced watering (depending upon how constructed)
- increased soil aeration
- reduced pests
- improved growing surface for trailing plants such as squash.

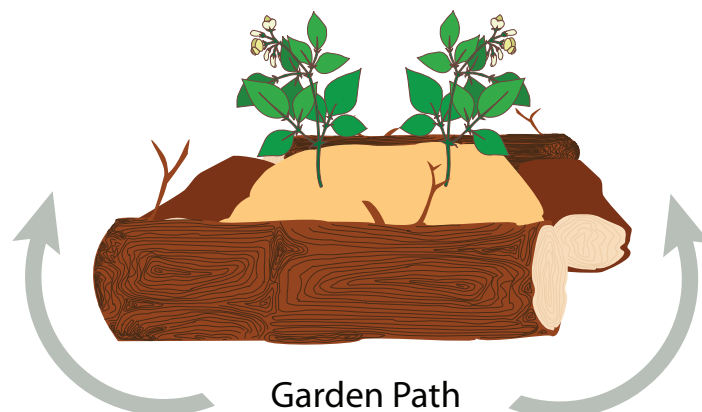

Disadvantages of raised beds:

- require more materials than regular beds
- require more labor than regular beds.

To construct a simple, raised bed dig out the bed and mix in extra soil and compost to increase its height to the desired level. As the compost decomposes and the soil compacts, the level will go down. To compensate for this add more compost regularly, especially after harvest when the bed is fallow.

Higher raised beds – higher than 20 cm. – should have structural edges, or walls. Make these from boards, logs, branches, palm leaves, large rocks, old metal or plastic roofing, and so on. If available, use a thin layer of plastic or woven palm leaves to line the sides (not on the bottom); this will help retain water and extend the life of walls made from wood or other organic materials.

d. Shade House Gardening

This method takes advantage of the shade. In sunny, tropical, and arid regions, there is often too much sun for the moisture available in the soil. This condition stunts plant growth. The shade house provides some partial shade during the hottest part of the day, thus saving precious water. In addition, a shade house is often necessary to start some plants, and can serve as a nursery for seedlings.

To use a shade house, first determine the path of the sun, as the structure must provide shade from the sun during the hottest part of the day. Construct a simple rectangular structure poles and a roof of loosely woven palm leaves. Take care to let in light during the cooler morning and afternoon hours. Experiment with various plants and determine which do better in partial shade rather than in direct sunlight.



2. Basic Plant Science

Understanding the basic parts of plants and how they function together will help you create conditions that are best for your garden vegetables.

The parts of a plant can be divided into two groups:

- vegetative parts: roots, stems, leaves and leaf buds,
- reproductive parts: flower buds, flowers, fruits, and seeds.

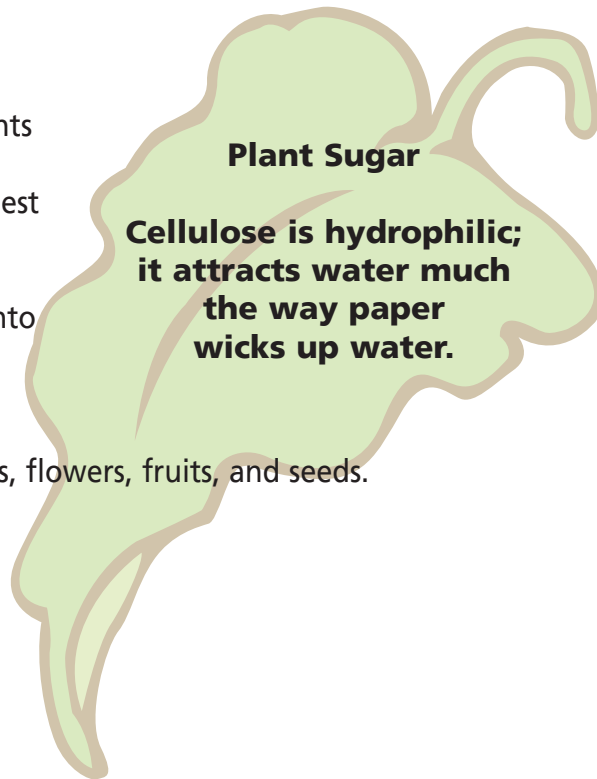

Principle Parts of Plants

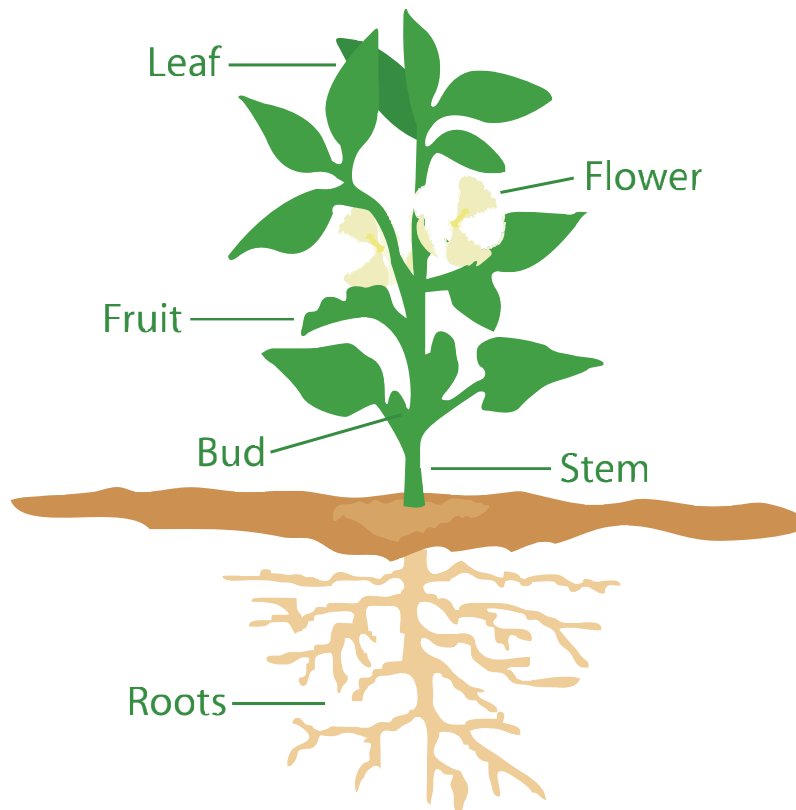

a. How Plants Grow and Develop

You need to know how plants grow and develop if you hope to take good care of them in your garden. In an attempt to provide this information, we begin with the three major functions that are basic to plant growth: photosynthesis, respiration and translocation of water.

Unlike animals, plants do not have a heart. Instead they take advantage of the unique properties of both plant structure and water.

Photosynthesis and Respiration: Energy Conversions for Growth and Food

The first process we describe is referred to as photosynthesis.

- Carbon dioxide (CO_2) diffuses through tiny pores (stomata) into the leaves.
- Within the leaves sunlight and chlorophyll transform CO_2 and water (H_2O) (obtained from the roots) into sugar (carbohydrates).
- Like animals, plants use the stored energy in sugar for growth.
- A by-product of this reaction is the release of oxygen (O_2) into the air.

The opposite of photosynthesis is respiration.

- Energy from the sun (visible light) is used to form energy storage molecules (sugars).
- The stored sugar energy is released and used.
- The by-products of respiration are carbon dioxide (CO_2) and water (H_2O).

Transpiration: The Plant's Water Pump

Transpiration is the upward movement of water through a plant, and every plant is composed of a water-transporting network of tubular "veins" (xylem).

Water and the nutrients it contains enters the plant through the roots. A combination of root pressure, capillary action, and water tension moves the water and nutrients up the xylem and throughout the plant, until the water is finally released as vapor through tiny holes (stomates). This evaporation process helps plants keep cool.

Photosynthesis

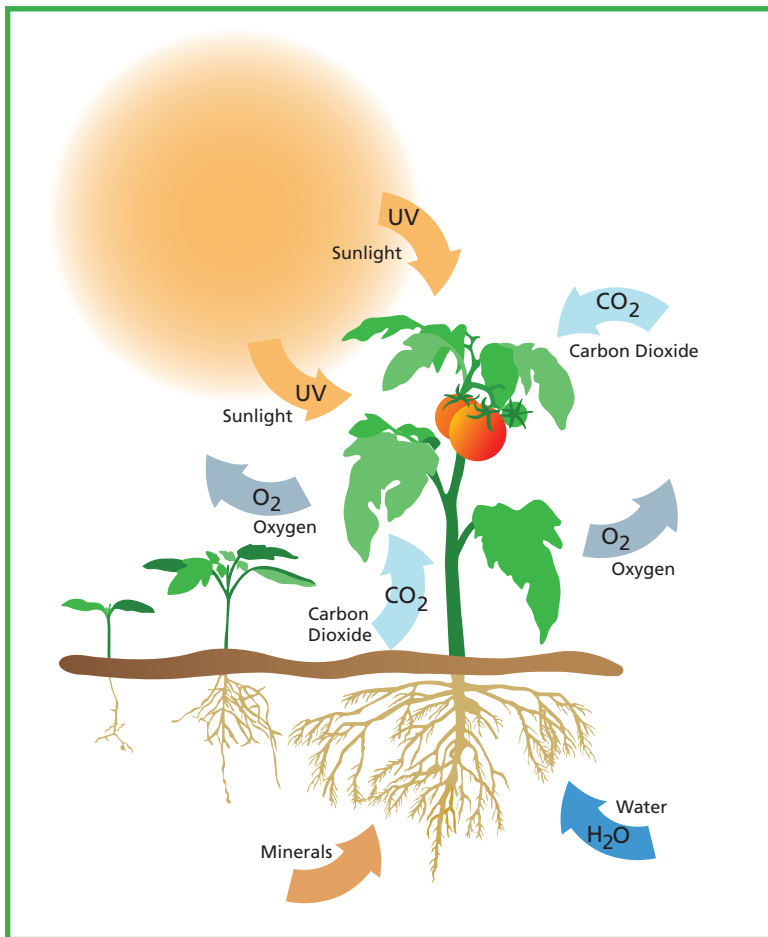

Transpiration

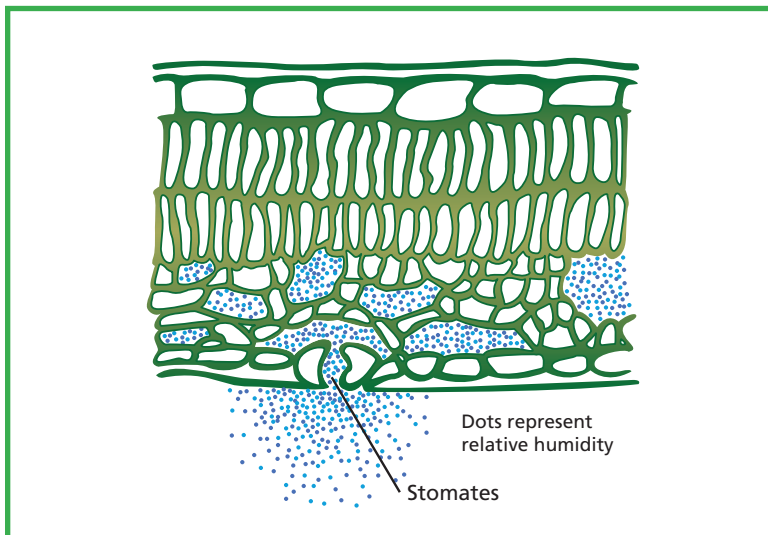

Some of the water is used in the plant cells for processes like photosynthesis, but over 90 percent of the water that enters plant roots ultimately evaporates through the stomates.



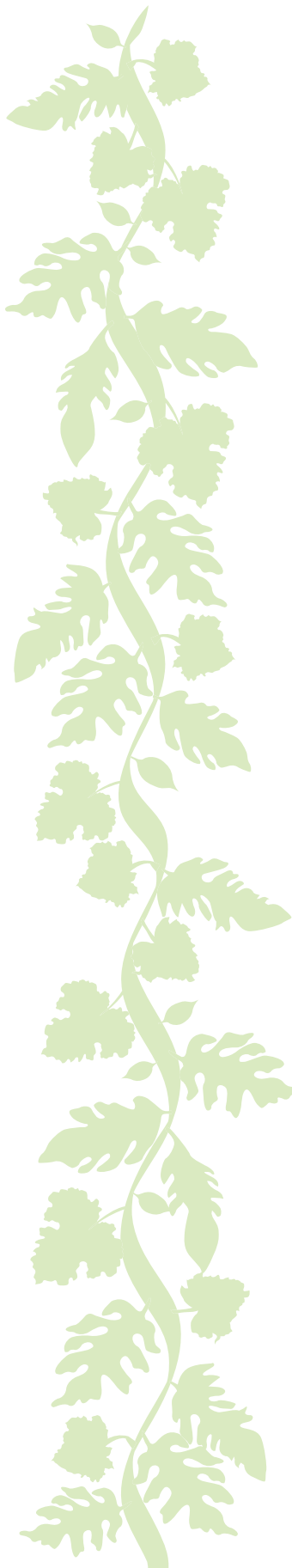

Photosynthesis and Respiration Compared	
Photosynthesis	Respiration
1. Food is produced.	1. Food is broken down for energy.
2. Energy is stored.	2. Energy is released.
3. Occurs in all cells that contain chlorophyll.	3. Occurs in all living cells.
4. Oxygen is released.	4. Oxygen is used.
5. Carbon dioxide is used.	5. Carbon dioxide is produced.
6. Water is released.	6. Water is released.

b. What Plants Need for Good Growth

Now that you have a basic understanding of a plant's "skeleton" and *how* a plant grows, let us explore what a plant *needs* to grow and prosper.

Vegetables and fruits come from many different plant families. We eat many parts of plants – leaves, seeds, fruits, roots, tubers and flowers. Most plants need full sun, but some can tolerate or even prefer shade. Some vegetables and fruits grow well in cool weather. Others like it hot. Finally, plants differ in hardiness. Some can tolerate cool temperatures, while others die at the first frost.

Despite these differences, all plants need certain things to grow, and how well a plant grows depends on the environment. Five factors influence the environment around a plant and the plant's growth:

Moisture + Air + Nutrients + Temperature + Light = Environment.

If any factor is less than ideal, it will limit a plant's growth. A smart gardener manages the plant's environment so the plant grows well. These factors are now described.

Moisture (Water)

Water is essential for plant life and is the major part of all living cells. As mentioned earlier, water is important in photosynthesis; it moves nutrients throughout the plant, and it helps the plant control its temperature.

Air

Air is made up of many kinds of gases, including nitrogen, oxygen and carbon dioxide. Plants need carbon dioxide for photosynthesis. In a greenhouse that is too airtight, lack of carbon dioxide can limit plant growth. Oxygen, necessary for respiration, is rarely a limiting factor. Plants usually give off more oxygen than they use.

Nutrients

Like animals, plants require certain nutrients for healthy growth. Sixteen nutrients are necessary:

Nutrients Required by Plants			
Non-mineral Nutrients	Primary Macro-nutrients	Secondary Macro-nutrients	Micro-nutrients
Needed by the plant in large amounts. <i>Provided by the air.</i>	Needed by the plant in relatively large amounts. <i>Provided by the soil and compost.</i>	Needed by the plant in large amounts. <i>Provided by the soil.</i>	Needed by the plant in relatively small amounts. <i>Provided by the soil.</i>
H Hydrogen O Oxygen C Carbon	N Nitrogen P Phosphorus K Potassium	Ca Calcium S Sulfur Mg Magnesium	B Boron Cl Chlorine Cu Copper Fe Iron Mn Manganese Mo Molybdenum Zn Zinc

Among these nutrients, nitrogen (N) is often the most scarce. A simple and effective way to increase nitrogen in your garden is to grow leguminous "green manures" such as Angolan peas (*cajanus indica*) or ground nuts (*arachis hypogea*) 6-12 months before you plant. This is very important if you notice a decline in productivity or yellowing of leaves, even after you have added compost.

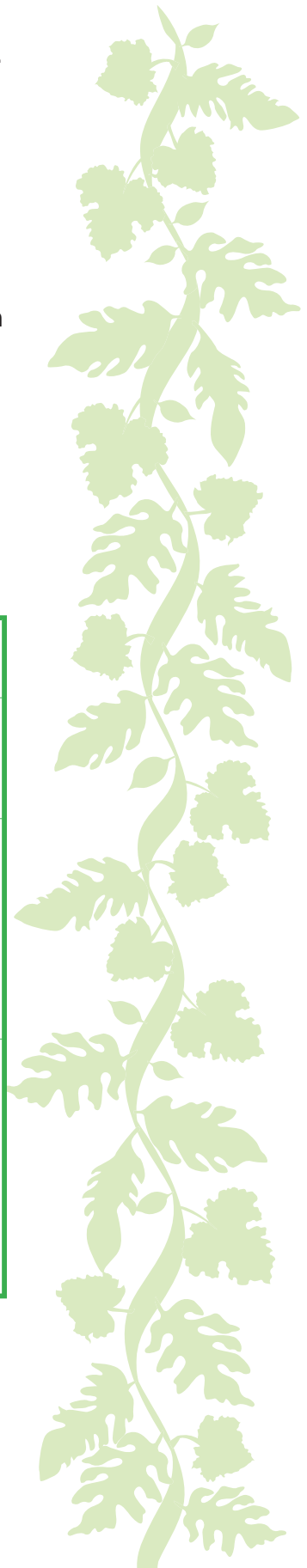



Plants obtain all mineral nutrients from the soil, thus a healthy soil is vital for healthy plants and high produce yields. Soil fertility varies widely, and without official soil tests it is difficult to know how good your soil is. Nevertheless, you can make excellent soil easily by adding compost.

Temperature

Plants have a comfort zone, much like people. Extreme temperatures (both hot and cold) stunt growth, resulting in poor quality plants. Some plants such as tomatoes, peppers, eggplant, cucumbers, and melons prefer warmer temperatures, and are best suited for the hottest growing season. Others such as lettuce, spinach, Swiss chard, and broccoli prefer cooler temperatures and are better suited to the cooler part of the growing season.

Light

Both quantity and quality of light have a major effect on plant growth.

- Light quantity refers to the amount of sunlight. Of course, this varies with the seasons of the year. The more sunlight a plant receives, up to a point, the more food it can produce.
- Light quality refers to the color or wavelength of the light that reaches the plant surface. It affects growth and flowering.
- Photoperiod refers to the length of day and night, which affects flowering and other events in some plants.

3. Compost: A Recipe for Success in the Garden

Compost is created by combining organic materials to make a natural fertilizer. It is easy and costs nothing but can make a big difference in how well your garden produces. Compost can be made with or without animal dung.

The decay of leaves, plant stalks, grasses, fruits and vegetables creates a nutrient-rich compost. When you add this compost to your garden you reintroduce required nutrients.

It is important that all of these essential ingredients be present in compost:

Air + Water + Carbon + Nitrogen + Microorganisms + Moisture = Compost

Microorganisms such as fungi and bacteria make the materials decompose. After the microbes begin the decomposition, larger organisms such as worms and insects also help to break down the organic materials.

From the organic compost materials, the microbes use the carbon (C) for food and the nitrogen (N) to build proteins. Without both types of materials (such as dung that is high in nitrogen and dried grass that is high in carbon), the microbes cannot do their job, and the compost process will be slow.

a. Compost Materials

While anything that was once alive can be composted, you should not put everything in your pile. These items are not good for the compost:

- protein such as meat scraps and bones; they will attract unwanted animals
- cat, dog, or human dung, as it may contain disease
- diseased plants of the tomato family

Compost Materials	
"Green Materials" High in Nitrogen	"Brown Materials" High in Carbon
<i>Comes from things that are green or relatively fresh.</i>	<i>Comes from things that are brown or drying up.</i>
animal dung <u>ok</u> : dung from cattle, chicken, goats <u>not ok</u> : dung from cats, dogs, or humans kitchen waste banana peel coffee or tea grounds egg shells fruit waste green leaves green weeds	bean pods corn stalks dried grasses dried leaves millet stalks

Large materials like sticks and big chunks of wood will take longer to break down. If these are used in the compost, use a machete to chop the larger materials into smaller, finer pieces; this will speed up the composting process. Palm leaves and dead logs will rot in the garden, initially providing mulch and later providing compost. Most dead trees decompose quickly in the tropics and can act as markers or barriers in the garden.

Smaller materials like sawdust or chopped leaves have more surface areas; this means the microbes have more area available on which they can do their work, and the materials will break down more quickly as a result.



Moisture

Good compost will be made when the compost materials are damp, not wet. If it is too wet, the decomposing material will have a foul odor and be cool in the center. If it is too dry, the material will not break down quickly into compost. During the rainy season, cover the materials with a layer of grasses or long leaves to shed the extra rain. In the dry season, covering with leaves will help keep the moisture at the best level.

After several weeks turn and mix the compost to accomplish two important steps. Turning will start the heating or decomposition process again and will provide you with an opportunity to check the moisture level. Add dry leaves if the compost is too wet. Sprinkle it with water if it is too dry.

Wood Ash

Sprinkle a little clean wood ash on the layers of materials when starting compost. Clean means no plastics have been burned in the ashes. Ash neutralizes the natural acidity that builds up during the composting process. While adding ash is not absolutely necessary, doing so may make the compost evolve more quickly. A little calcium (often called "Cal") or limestone (often simply called "lime") can also be used in place of ash to neutralize the compost.



b. Starting the Compost

It is very important to add some completed compost as a starter for the whole process. If you have no mature compost, add some good garden soil. This introduces the bacteria that are necessary if the decomposition process is to proceed quickly.

A compost can be set up as a compost heap or a compost pile. Climate and resources will determine what is most appropriate. Compost can be made with or without animal dung, which is considered a green/high nitrogen material.

Make a Compost Heap or Pile

1. Cover an area 2 meters x 2 meters square with a thick layer of brown/high carbon materials.
2. Add a layer of green/high nitrogen materials.
3. Sprinkle with wood ash, calcium, or limestone.
4. Add a few full shovels of finished compost or good garden soil.
5. Repeat the process until the pile is heaped high.
6. Water well and cover.
7. Turn the pile in a few weeks, adjust the moisture level and cover again.
8. Turn one more time.
9. After several more weeks the compost should be complete and ready to use.

Make a Compost Pit

1. Choose a place at the edge of the garden to build a compost pit.
2. Dig a pit 2 meters long x 2 meters wide and 1 meter deep.
3. You may build a shade structure to conserve moisture.
4. Mix two parts brown/high carbon materials to one part green/high nitrogen materials.
5. Let the mix rest for 1-2 weeks until it breaks down. Move it to another pit and begin again.
6. You may want to make several compost pits so that you have compost at different stages and ready for fertilizer when you need it. If so:
 - Spread compost from pit 3 on the garden.
 - Move compost from pit 2 to pit 3.
 - After 2 weeks, move compost from pit 1 to pit 2.
 - Start new compost in pit 1.



4. Future Plantings

a. Saving Seeds

Saving seeds from your harvested crop is the traditional way to ensure you have seeds to plant for the next season. This only works with open-pollinated seeds, meaning plants that self-pollinate or are pollinated naturally by the wind or insects. Some commercial seeds that you may buy are hybrids, meaning they are a cross between two different varieties. While they may be good plants, they will produce seeds that are sterile or of unknown quality. Whether the seed is hybrid should be a major consideration when buying seeds.

Make plans to save seeds while you are planting the garden, keeping in mind that you will select out plants to save for seed and, therefore, will not be able to eat the fruits or vegetables from these plants. Select the best plants and biggest fruits or vegetables to save for seed.

Further, save seeds from plants that go to seed quickly, those in the middle, and those at the end of their cycles so you will have a diversity of plants that will mature at different times. You want to have diversity in your seeds and plants so that you have a diverse and consistent garden. Finally, once you have selected a plant, be sure to mark it with a stick or other method so that everyone knows not to harvest it for food.

It is easy to save seeds from certain vegetables and difficult to do so for others. Two plants that are easy to start with are beans and peppers. First, let the mature bean pods dry and the peppers turn red. Then collect and save the dry seeds until you are ready to plant a new crop.

Tomato and cucumber seeds are also easy to save. Collect seeds from the mature fruits and place them in a small amount of water. Then place them in the sun for several days. The fungus that forms on the water will help preserve your seeds and prepare them for new growth. After three or four days, rinse your seeds, dry them, and save them for your next planting.

Seeds are often produced in abundance, and they are easy to collect, store, and distribute. These are just some of their advantages over vegetative propagation (discussed below).

For more information on saving seeds refer to *Basic Seed Saving* by the International Seed Saving Institute. (Complete citation in References Section.)

b. Direct Seeding in the Garden Bed

Some plants such as carrots, radishes, and spinach do best when directly seeded into the garden because they do not transplant well. For others (next page), it is better to start seedlings in a protected seedling nursery, where you can concentrate the tender young seedlings and more easily control the growing conditions such as water, soil, and sun.

Make a hole in the soil with a small stick or pencil, 2-3 times the size of the seed. Place the seed in the hole and cover with soil. Never pack the soil, especially a wet soil. Refer to the section on spacing requirements located earlier in this Manual.

Plant a small seed like carrots very shallow, barely 0.5 cm. below the surface. Plant a larger seed such as beans 3-4 cm. below the surface. Some seeds may be soaked in water to improve germination; for example, soak beans and peas one hour in warm water before planting.

After the bed is seeded, lightly tamp down the area planted to help the seed make good contact with the soil.

Vegetables for Transplanting from the Nursery vs. Direct Seeding			
Best for transplanting seedlings		Best for direct seeding	
Vegetable	Seedlings ready for transplant	Vegetable	Seedlings ready for full sun
cabbage	3-5 weeks	amaranth	1-2 weeks
eggplant	4-6 weeks	beet	immediately
kale	3-5 weeks	carrot	1-2 weeks
okra	4-6 weeks	green bean	immediately
onion	3-6 weeks	pumpkin	2-3 weeks
pepper	5-6 weeks	spinach	3-6 weeks
tomato	4-6 weeks	squash	2-3 weeks

c. Vegetative Propagation

Vegetative propagation is the second traditional way to produce more plants for future planting. Not all plants can be propagated by vegetative means, but those that can (e.g., bananas and sweet potatoes) have some important advantages over seeds. First, cuttings from the parent plant will "breed true." This means the resulting plants will exhibit exactly the same qualities as the parent plant. In addition to retaining the same genetic line, numerous cuttings can be taken from the parent plant throughout the growing season and lifetime of the plant. Seeds can be obtained only later in the growing season (often at the end of the plant's life cycle) when the fruit has matured.

Plants resulting from vegetative propagation...

...are genetically identical to the parent plant.

Seedlings and a Seedling Nursery

You can make a small shelter out of poles and shade netting and/or leaves to serve as the protective shelter for a nursery. Constructing a simple roof of grass or palm leaves can make a good alternative to shade netting.

Note: Some light should penetrate through the shading roof; do not make the roof too dense.



To construct your seedling nursery get a few good strong poles with a forked end. The poles should be about chest height so that when they are put into the ground they are about waist high. You may place a few poles across the top to serve as a frame for the shading roof. The shelter does not need to be very big for an average school garden. One meter wide by three meters long should provide plenty of space and transplants for a traditional garden.

Growing, Placing and Caring for Transplants

You may start transplants in individual containers, such as metal cans or you may start them directly in the soil in the ground of the nursery. If you use containers make sure you make holes in the bottoms so excess water can drain out. Start your transplants early enough so they will be ready for planting when the time is right.

Growing seedlings in the nursery requires some dedication and skill. Melons, cucumbers and squash can be difficult to transplant. Grow them from seed in large containers so they only have to be transplanted once: right into the garden when the seedlings are ready. Or direct seed these plants right into the garden.

When starting plants, consider the soil. To use ordinary topsoil from your garden, sterilize it first so it is free of disease organisms. It is easy to sterilize the soil: bake it in the sun for several days under a sheet of clear or black plastic, or under tin roofing material.

Enrich the sterilized soil with good amounts of organic matter such as compost or very well-rotted dung. This mixture is important, whether you are planting in containers or directly in the ground.



Steps for Starting Transplants

1. Mix ½ half sterilized garden soil with ½ good compost or well-rotted dung for your seedling germination soil.
2. Placement
 - In garden:
Make rows 15 centimeters apart and 0.5 centimeters deep across the nursery planting bed.
Sow 2 seeds per 1 centimeter in the row.
 - In containers:
Make holes in the bottom for drainage.
Fill the container with seedling germination soil until it overflows, and then pat it down gently.
Sow a number of seeds as appropriate for the size of container.
3. Cover seed with the soil no deeper than twice their thickness. Press lightly. Water gently with a watering can or spray lightly over a palm leaf. Take care not to water with a strong stream or you may erode the soil and seeds away.
4. When seedlings emerge you must thin them to allow enough room for a healthy transplant to grow. Whether in the garden or containers, this means 1 seedling every 2 centimeters. Larger seedlings may need additional thinning. Overcrowded plants will look thin and spindly and will be less healthy.

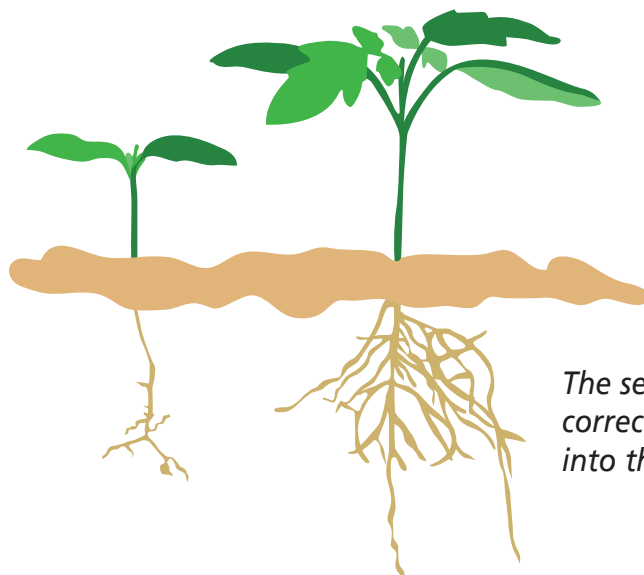
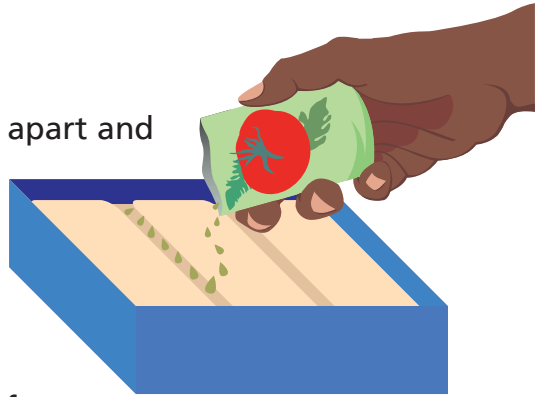

The seedling on the right is the correct size for transplanting into the garden.

5. Reduce watering and expose the containers to a little more sun each day for a week before transplanting. This will toughen the plants and reduce the shock of transplanting.

d. Transplanting into the Garden

Have the garden soil ready before you transplant. Transplant in late afternoon or early evening; this will give the tender young transplant the night and early morning to recover and it will be less likely to wilt before being exposed to the full sun.



1. Dig a hole large enough to hold the transplant roots. Add a handful or two of compost to the transplant hole to help seedlings get off to a good start. Fill the hole with water and allow it to drain. This will ensure that the soil surrounding the transplant will have adequate moisture.
2. Transplant only the most healthy and vigorous seedlings. This means the seedlings must have good roots and at least two sets of well-developed, true leaves.
3. Take special care to handle the transplants. To avoid damaging the roots or stems, you should handle them gently by the leaves, not the stem. Remove the seedlings with a trowel, taking along a good size root and soil ball. This will help minimize the "transplant shock" to the seedling.
4. Except for tomatoes, replant all seedlings at a depth that matches their depth in the seedling container. Tomatoes are an exception to this and can be planted 4 cm. or so deeper than they were in the seedling bed. Tomatoes will sprout new roots from the stem and have a stronger, deeper root system.
5. Space the plants according to the guidelines on page 23.
6. Press soil firmly around the roots of transplants and water lightly to allow soil to settle around the transplant.



Water each plant regularly to keep the soil from drying out. An occasional watering with a very dilute fertilizer made from animal dung tea may help if your plants are growing slowly and lack a healthy green color.

Refer to the section: *Natural Fertilizers for* recipes to make fertilizer teas.

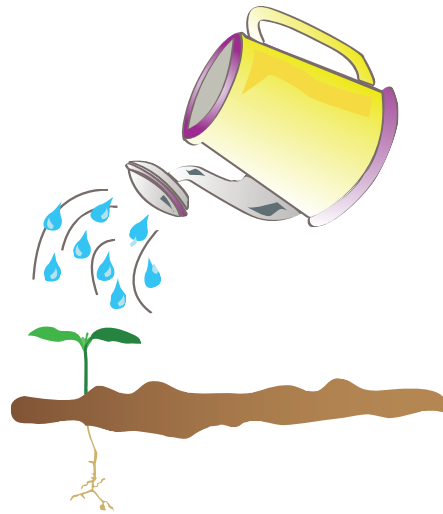

e. Protecting New Transplants from the Sun

Plants recently transplanted from the shade nursery are not accustomed to the full sun. To prevent new transplants from wilting and to allow them to slowly adjust to the full sun of the garden, use small branches with leaves attached to give them some shade for a few days.

Even with this care, seedlings will undergo some transplant shock from being exposed to the harsh sun of the garden, as opposed to the protected environment of the seedling nursery.

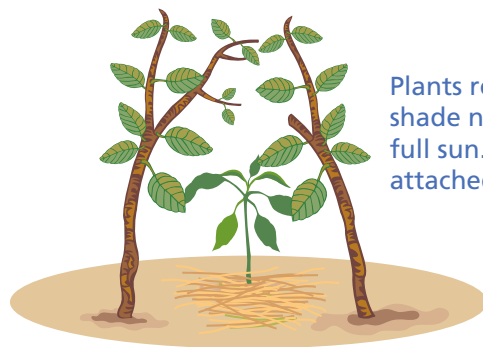

Plants recently transplanted from the shade nursery are not accustomed to the full sun. Use small branches with leaves attached to shade the seedlings for a few days.

5. Agro Forestry

Agro forestry is the combination of a garden mixed with trees. In Central America this technique was developed over a thousand years ago and gave rise to sophisticated "kitchen gardens" which provide a wide variety of native foods including avocados, papayas, chocolate, and vanilla.

Trees can provide many benefits to your garden's ecosystem. Wood from branches that have died back can provide fuel for cooking, as can dried leaves, which are also useful for mulch or in compost. At the same time, nutritious and flavorful additions to the school lunch can come from the fruits and nuts produced by the trees, and the honey produced by bees as they pollinate the trees' flowers when it is in bloom.

As discussed under the section on Shade House Gardening, some locations benefit from partial shade. Gardens in these situations can use partial shading from selected canopy trees, just as is the case with coffee and cocoa plants in many regions of the world. Before you select a specific tree think about what species could yield the most for your garden. Do you want fruit only? Firewood? Shade? Choose wisely!

Transplanting Trees

To transplant a tree to your garden:

- Be sure that the tree is compatible with your garden. When it matures will it shade your garden? Does it form root sprouts that will grow into new trees? Could it eventually monopolize your garden? Does it suppress other plants from growing by emitting plant growth inhibitors (allelopathic)?
- Look at the tree you will be bringing into your garden and observe its natural environment. Notice things such as the direction it is facing, if it is in a shaded or sunny area, or if the ground is moist or dry. If possible, replant the tree so it is placed in a direction that matches the original orientation.



- 
- Look at the plants that are growing next to the tree. If possible, take some of the earth the tree was growing in, as well as the plants surrounding it (excluding weeds). Bringing some of the tree's original environment along with it gives the tree an easier transition from its old home to its new home. Simply put: there is already an ecosystem set up for the tree; if you bring some along with the tree, it will provide more benefits.

Small trees are far easier to transplant than those which are more mature. Plant smaller trees in your garden every year or two so that you have trees of different ages. Then you will have fruit to harvest every year. When a tree stops bearing fruit, remove it and plant a new one in about the same place.

6. Steps to a Healthy Garden

Plan your garden to include vegetables and plants that are indigenous to the area; they will be a good source of food. When you plant native plants they are already in balance with the natural environment. Through genetic and biological diversity the plants have characteristics that help them to be healthy and to grow well for that particular environment. Besides needing less watering and weeding, native plants are more likely to be disease resistant.

a. Know Your Garden

Smart gardening is based on understanding nature's interactions, and savvy gardeners know what is happening in their gardens. They regularly inspect the plants for insect damage, for disease, and for other signs indicating that intervention is needed (such as plant wilt, for example). Many times pest problems are cyclical; they repeat at the same time or same season of the year, or during periods of similar weather, for example, the rainy season.

Do not turn to chemicals at the first sign of a pest. The more often we use garden chemicals, the greater the risk we have of running into health, environmental or resistance problems. Besides, most insects are helpful; only a few are harmful. Usually a garden can tolerate some harmful insects without experiencing significant damage.



**To learn about
your garden...**

**get down on your
hands and knees
and look closely!**

It is important to make your garden a healthy place for your plants and a place that is unattractive to pests.

- Choose the right plant species.
- Provide the right amount of moisture.
- Do not over- or under-fertilize.
- Rotate vegetables.
- Keep your garden clean. Remove weeds because they can harbor disease and insect pests.
- Time plantings to avoid peak insect infestations. Sometimes the most destructive phases of an insect's life are brief and predictable. Plant so that you avoid pest attacks.
- Encourage naturally occurring and beneficial insects, as well as frogs, toads and other insect-eating creatures. These are your garden's best friends. Certain insects cause no damage and actually do good work in the garden, such as eradicating other insects that injure plants. Lady beetles, lace wings, certain mites, praying mantises, braconid wasps, assassin bugs, and minute pirate bugs are all "good bugs."
- Identify the problem. Do not jump to conclusions. Think back. Did a past experience with this pest require control? Did you have trouble with this pest last year?
- Determine the problem potential. Is the current problem likely to become serious enough to justify some kind of treatment? Sometimes when you first encounter a problem it will have already run its course, meaning no further damage may occur. Sometimes the damage will be minimal. Decide what you and your garden can tolerate.
- Select the least toxic approach. Try the simplest and safest control first. Observe results. Record your results for future reference. Besides detailing which plants were attacked by which pests, include information such as actions taken and the outcome. Keep in mind that overuse or continuous use of pesticides or herbicides can lead to pesticide or herbicide resistance in insects and weeds.

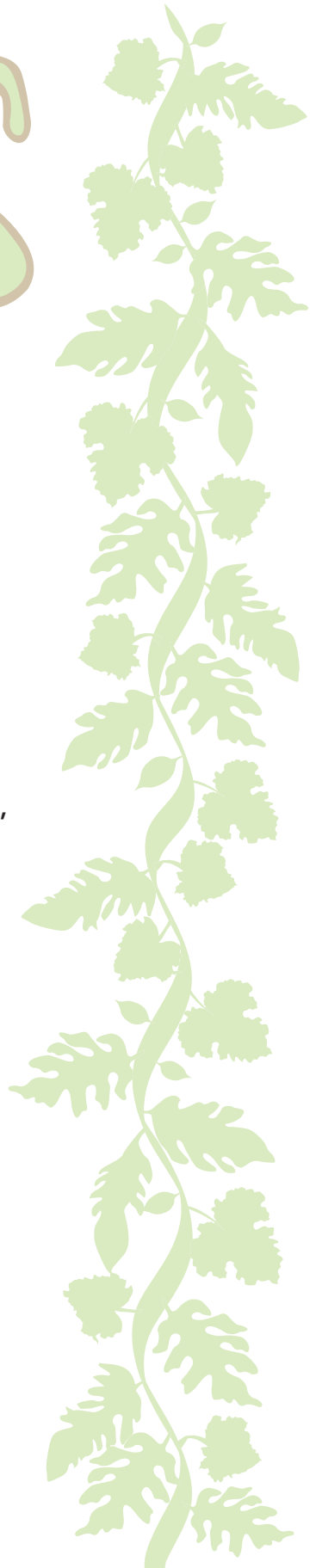
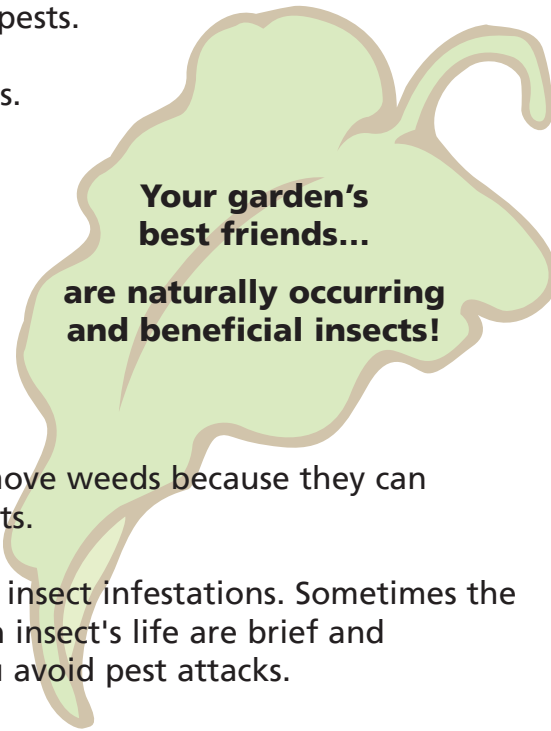

b. Applying Natural Fertilizers

The ecology of your garden is a great source of natural wealth for fertilizing your plants without the expense and negative consequences of artificial or chemical fertilizers. Prepare these recipes for compost tea/dung tea or plant tea; they are ready-to-apply fertilizers that cost nothing but have great yields.

NATURAL FERTILIZER "TEAS" **Recipes and Uses**

COMPOST TEA or ANIMAL DUNG TEA

Place 1 full shovel of animal dung or compost in a large bucket.

(Bucket size: approximately 20 liters.)

Cover loosely or not at all.

Stir once a day.

Allow this "tea" mixture to ferment for two weeks.

After fermentation:

Strain or filter the tea.

Dilute 1 part tea to 2 parts water.

Apply:

Use to water large plants.

NOTE: Do not use dung from dogs, cats or humans.

PLANT TEA (also called "Green Manure")

Chop green sappy leaves into small pieces.

Place 1 full shovel of choppings in a large bucket.

(Bucket size: approximately 20 liters.)

Cover loosely or not at all.

Stir every three days.

Allow this "tea" mixture to ferment for two weeks.

After fermentation:

Strain or filter the tea.

Dilute 1 part tea to 2 parts water.

Apply:

Use to water large plants.

c. Controlling Pests

Pests are objectionable organisms that can harm crops. As such, a pest can be a plant, an insect, or an animal. When most people think of pests they think of insects, but fungi, viruses, bacteria, weeds, rodents and other organisms can be as destructive as insects. They may all compete with us for food, inflict injury, or just be annoying. Fortunately, we can control pests or limit their impact without damaging our environment.

Insects and other creatures are an important part of a healthy ecosystem. A pest-free garden is expensive and impractical. In fact, a pest-free garden is actually undesirable. Your goal should be to keep pest populations below the level at which they cause unacceptable damage. If you allow a low level of pests to survive, some of their natural enemies will also survive. That is good!

In the village, it is usually not practical to control pests with chemical pesticides, which are often unavailable and expensive. When a pesticide is used improperly negative effects can result: it may leave harmful pesticide residues on the food; it may make handling the plants more hazardous; and it may harm beneficial insects, earthworms, birds and even livestock.

Insects

Insect pests can be controlled in two ways:

1. non-toxic control methods such as natural pesticides
2. chemical pesticides.

The natural methods are always less expensive and more benign. Here is a list of non-toxic methods:

- Prune out insect-infested areas of plants.
- Dislodge insects gently with a stream of water or a brush.
- Handpick insects from plants and drop them into a bucket of soapy water.
- If cutworms shear off your transplants, gently dig in the soil to find and kill the cutworm. Then you can transplant another plant.
- Remove diseased plants and harvested plant remains.





Remove Spent Plants to Reduce Disease and Insect Carryover

Remove plants in the garden when they stop producing fruits and vegetables.

For example, after harvest remove all of the cucumber and squash vines.

Compost these plants if they have not been infected by disease or insects. If diseased, dispose of far away from the garden.

Weeds

Weeds can be controlled in various ways:

- Pull by hand.
- Cultivate with a hoe where appropriate.
- Use mulches generously.
- Use chemical or natural herbicides.

Diseases

A plant disease is the disturbance of the physiology, structure or function of the plant.

There are two causes of plant diseases.

1. Biotic causes involve infectious pathogens that spread from plant to plant. The three most common are: fungi, bacteria and viruses.
2. Abiotic causes are non-living; including such things as excess moisture, shortage of plant nutrients and heat extremes.

Disease symptoms are the changes in the plant produced by the disease. Usually these are discolored, malformed or dying regions on plants.

Examples are:

- Necrotic or dead areas: rots, spots and blights.
- Discoloration: yellowing or chlorosis of leaves.
- Galls are overgrowth of plant tissue.
- Stunting of plants or general overall poor growth.
- Wilting of the whole plant.

For more see the illustration of plant symptoms which follows.

Plant Diseases: Signs and Symptoms

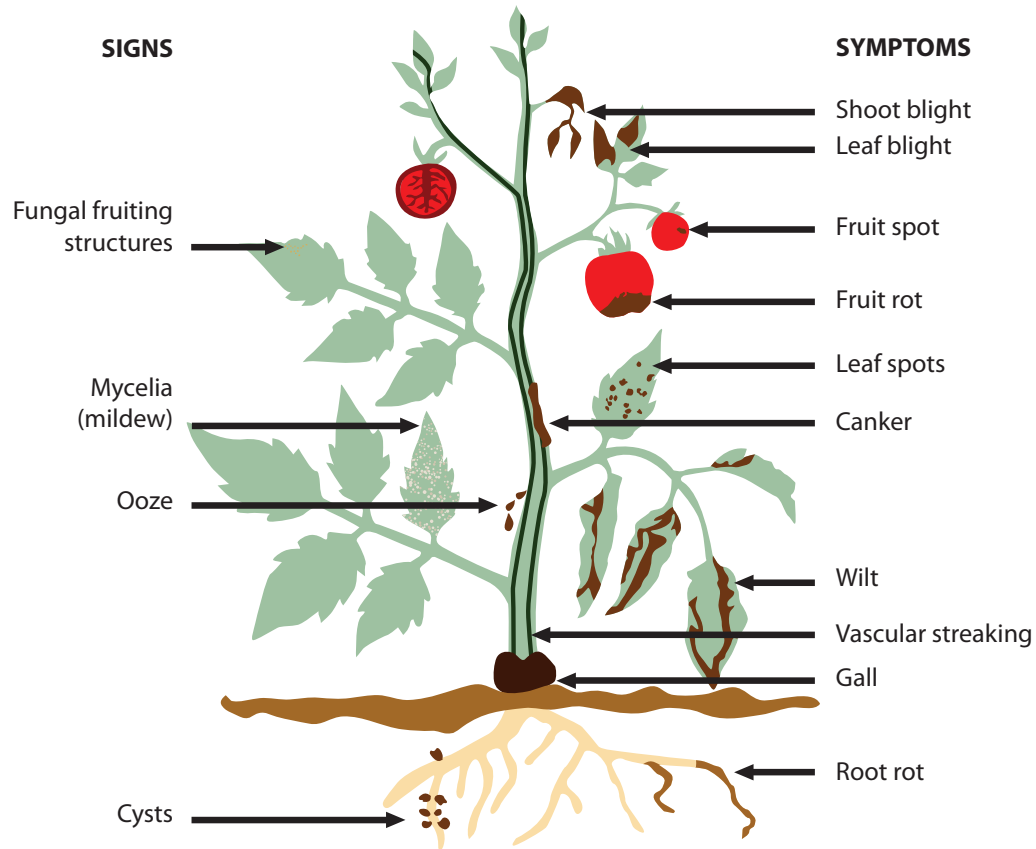

Diseases can be controlled in various ways.

As is shown in this Disease Triangle illustration, there are three main factors in disease prevention and control. They are listed on each corner.

A susceptible host must be planted, the pathogen must be present, and the environment must be favorable for the disease.

All three factors must be present or there will be no disease, as is illustrated inside the center of the triangle.

Plant Diseases

The Disease Triangle

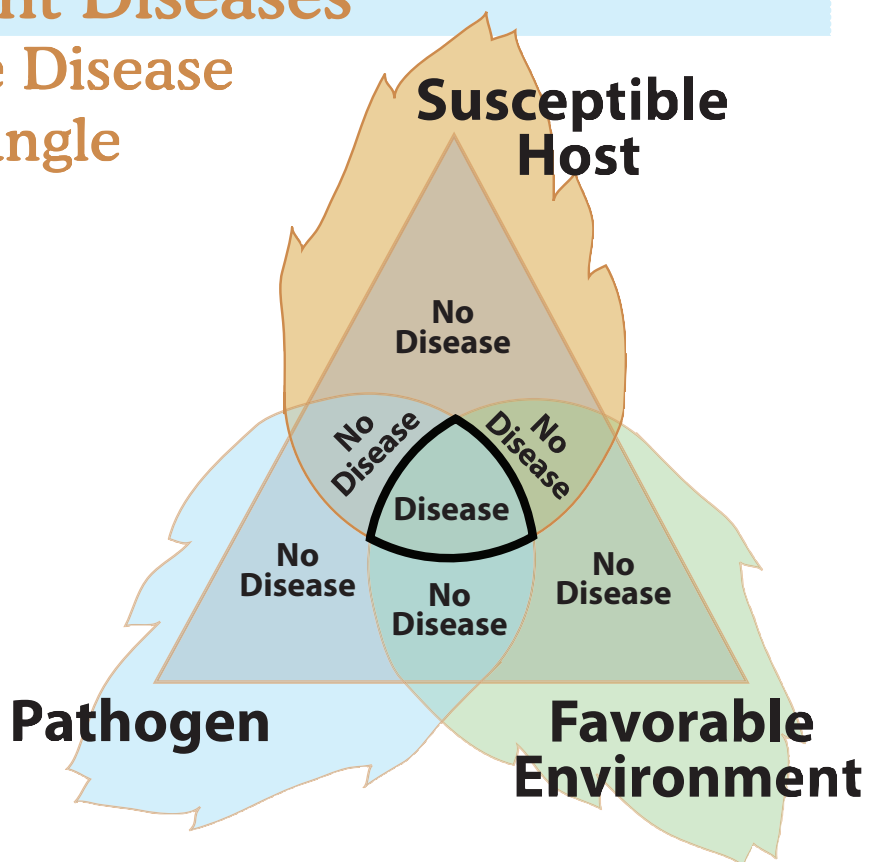

What can you do? Here are a few ways to control each factor;

- Susceptible Host – Plant disease-resistant varieties or vegetable.
- Favorable Environment – Use proper watering techniques; time watering so that foliage dries by nightfall and allow adequate space between plants; prune for good air circulation.
- Pathogen – Maintain clean plantings to reduce pathogen amount; remove diseased plants and harvested plant remains out of the garden; rotate by planting different crop families after one another; use organic homemade sprays.
- Chemical pesticides are the last option.

d. Natural Pesticides

Always test a homemade spray before using it. To do so, place a little of the natural pesticide on a few leaves of several types of plants, wait a day, and check for damage. If no problems occur, go ahead and apply the natural pesticide.

To make these recipes stronger, add one small spoon of high-quality cooking oil. Remember: never treat during the hot and sunny part of the day, especially if the mixture contains oil. Doing so could cause leaf burning.

Rain will rinse off the insecticide; reapply when necessary. Re-check plants often and apply to new plant growth.

The following recipes are for simple and natural pesticides which are safe to use in the garden.

START with SIMPLE NATURAL INSECTICIDES

NATURAL TEA

Crush the leaves and make a strong tea from marigold, cosmos, or licorice basil.

SOAPY MIXTURE

To control soft-bodied insects like aphids, use a small spoon of soap in four liters of warm water.

After preparation, apply to portions of plants being attacked by pests (include both upper and lower sides of leaves). Use a small mop, broom or brush made from twigs, grass, or strips of cloth tied together. Rain will rinse off the insecticide; reapply when necessary.

Always test a homemade solution before using it. To do so, apply a little of the solution to a few leaves of several types of plants, wait a day, and check for damage. If no problems occur, go ahead and apply the solution.



CONSIDER these NATURAL REPELLENTS

A GARLIC SOLUTION...

will repel aphids, caterpillars, cutworms and flea beetles. Put 3 small spoons of chopped garlic and 2 small spoons of mineral oil in a pint of water for 24 hours.

A HOT PEPPER SOLUTION...

will repel aphids, beetles and thrips. Put 2 small spoons of chopped hot peppers, 2 small spoons of chopped garlic, and 1 small spoon of soap in a liter of water for 24 hours.

A NEEM LEAF SOLUTION...

suffocates soft-bodied insects like aphids. It also is effective as a repellent to many insects early in their life. Chop the leaves and seeds of the neem tree into a bucket of water to soak for a day.

METHOD

1. Strain the mixture through a cloth (a sock will work).
2. Mix the first or second pesticide mixture in a bucket of water; the neem leaf spray need not be diluted.
3. Apply to portions of plants being attacked by pests (include both upper and lower sides of leaves). Use a small mop, broom or brush made from twigs, grass, or strips of cloth tied together. Rain will rinse off the insecticide; reapply when necessary.

Always test a homemade solution before using it. To do so, apply a little of the solution to a few leaves of several types of plants, wait a day, and check for damage. If no problems occur, go ahead and apply the solution.

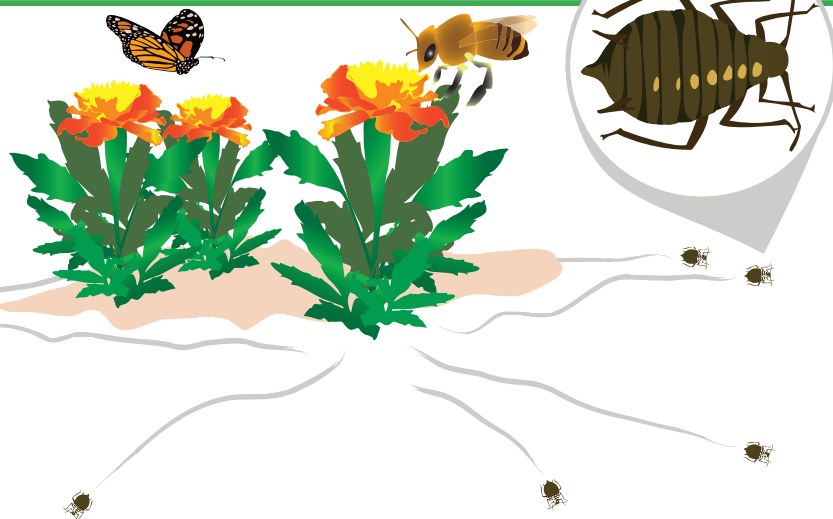

RECIPE for a NATURAL FUNGICIDE

INGREDIENTS

- 1 heaped spoon of grated soap
- 2 cups hot water
- 1 heaped spoon of sodium bicarbonate (baking soda)

METHOD

1. Dissolve soap in water.
2. Add baking powder and mix well.
3. Mix one cup of fungicide mixture with 10 cups (1 small bucket) of water.
4. Apply to portions of plants (including both upper and lower sides of leaves) before the disease progresses. Use a small mop, broom or brush made from twigs, grass or strips of cloth tied together. Rain will wash off the insecticide, so reapply solutions when necessary.

Always test a homemade solution before using it. To do so, apply a little of the solution to a few leaves of several types of plants, wait a day, and check for damage. If no problems occur, go ahead and apply the solution.

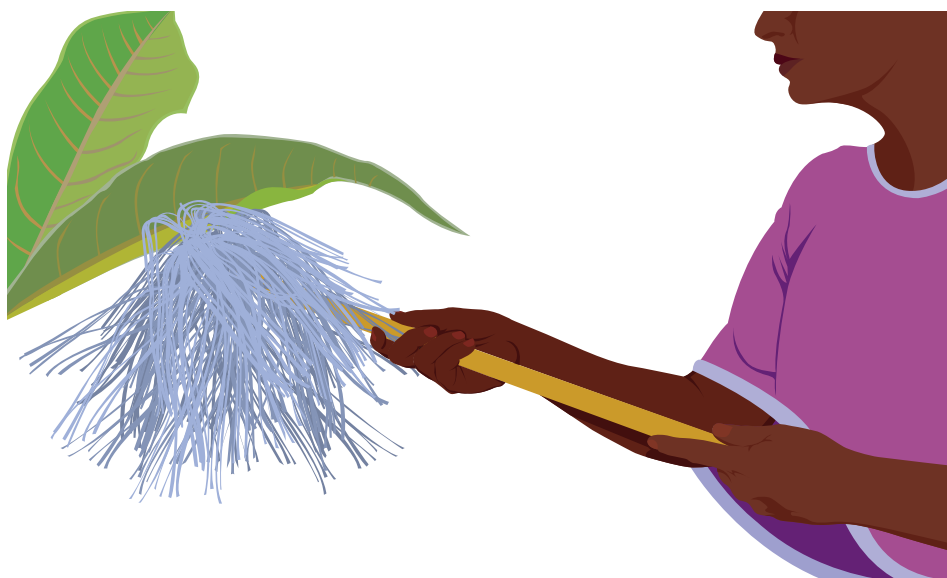



D. Nutrition

For many people around the world, food security is a problem. This means they do not eat regularly, or if they do, they are not always able to eat the right types of foods.

Food is important for far more than relieving hunger. All foods contain nutrients – including vitamins and minerals – that our bodies need. How our bodies use these nutrients is the science of nutrition. Food is also important to help boys and girls grow up strong and healthy. Eating the right foods gives us energy to do our work and to play. It can help people of all ages to avoid getting some diseases and can also help us get better if we are sick.

In this section we will review some of the basic theory of nutrition and learn how to make the most of the foods in our gardens and in Africa.

We can organize or categorize foods by the type of nutrition and vitamins they provide as well as by the types of food products that are derived. A combination of both methods helps to ensure that we choose balanced diets.

1. Types of Nutrients

Nutrition is the science of how food nourishes our bodies.

Foods are complex substances. You might enjoy food because it tastes good and satisfies you when you are hungry. But your body needs the substances in food to function.

All foods contain nutrients that your body cannot make. These nutrients and the energy they provide are essential to your health. During digestion, food is broken down into nutrients which are absorbed into your bloodstream and carried to every cell of your body, where the major work of body function happens. There are more than 40 nutrients in food that fit within six major groups. Each nutrient has a specific and unique function that works in partnership for good health.

Carbohydrates

Provide energy. Most fruits and many vegetables are good sources of carbohydrates. One type of carbohydrate is fiber. Fiber helps us digest our food and helps protect us against some diseases. Because fiber helps food move more quickly through our digestive system, many believe it helps prevent diseases such as colon and rectal cancer.

Good food sources: All sweet fruits, cereal grains (rice, maize, wheat, millet, etc.); and starchy roots (cassava, potatoes, yams) are the body's main source of energy, or calories.

Fats

Provide energy. Some fats are needed as building materials and help the body to use certain vitamins. They supply energy, too. But they have other uses. Fats help carry nutrients and are part of many cells in our bodies. There are many types of fats; some are beneficial and some can be harmful.

Good food sources: All vegetable and animal oils and fats; lard, butter, ghee, margarine; some meat and meat products; some types of fish; nuts and soybeans.

Minerals

Minerals have a role similar to vitamins. Each mineral helps you in different ways.

Calcium – Important for body maintenance and for strong and healthy bones and teeth.

Good food sources: Milk and dairy products; small fish eaten with bones; beans and peas; dark-green leaves.

Iron – A major component of red blood cells, necessary to keep all of the body's cells working properly. Iron is especially important for girls and women of child-bearing age. The body can use iron more efficiently if it is eaten along with vitamin C.

Good food sources: Liver, meat, whole grain cereals, fish, eggs, many legumes, green leafy vegetables and dried fruits.

Potassium – Maintains the body's fluid balance, a vital function. Also helps our body use carbohydrates and proteins.

Good food sources: Most fruits – especially bananas and cantaloupes; vegetables, dairy products, fish, lean meats and poultry.

Zinc – A mineral, that when used in combination with vitamin A, helps our body fight malaria and other diseases.

Good food sources: Cabbage, green beans.





Proteins

Proteins are made up of amino acids, the building blocks that build, repair and maintain body tissue. Proteins build and maintain muscle, blood, skin, bone and other tissues and organs in the body.

Good food sources: All types of meat, poultry, fish, beans, peas, soybeans, groundnuts, milk, cheese, yogurt and eggs.

Vitamins

Vitamins start many body processes by setting off chemical reactions in body cells. Each vitamin regulates different body processes. The vitamins and minerals in our foods help us.

Vitamin A – Needed for building and maintaining healthy tissues throughout the body, particularly the eyes, skin, bones and tissues of the respiratory and digestive tracts. It is also important for effective functioning of the immune system.

Good food sources: Breast milk, liver, eggs and dairy products; palm oil; many dark-colored vegetables (e.g. carrots, dark-yellow and orange sweet potatoes, pumpkin); mango, papaya).

Vitamin B complex: Thiamin, riboflavin, niacin, vitamin B6, folate, pantothenic acid, vitamin B12, and biotin. Needed for converting carbohydrates, fat and protein into energy and for them to build and repair the body's tissues. Folate, a type of vitamin B, is needed to make healthy blood cells. We need foods with vitamin B every day.

Good food sources: Dark-green vegetables, groundnuts, beans, peas, cereals, meat, fish, eggs, dairy products.

Vitamin C – Needed to increase absorption of dietary iron and for connective tissue, which binds the body's cells together. Speeds healing and boosts the immune system. We need foods with vitamin C every day.

Good food sources: Most fruits, especially citrus and guava, and many vegetables.

Vitamin D – Helps body absorb and use calcium.

Good food sources: Fish oils, eggs and milk; is also produced by the body when the skin is exposed to sunlight.

Vitamin K – Helps blood clot.

Good food sources: Leafy green vegetables, milk, soybean oil, eggs.

Fiber

While fiber is not a nutrient, it is critical to digestion. Fiber carries other nutrients, helps us feel full, and assists in digestion.

Good food sources: Whole grain cereals, starchy roots, fruits, most vegetables, beans, peas, oilseeds.

Water

Water carries nutrients and other body chemicals to your cells and carries away waste products. Water helps your body maintain normal temperature.

2. Types of Foods

To help us eat the right balance of these nutrients, we group foods into 5 main categories. Getting the right amount or a balance of food from each category is the key to eating right. It's best to eat foods from each category every day.

Dairy

Helps build your bones and keeps them strong. Calcium also helps your teeth. Younger children need 2 servings. A small cup (about .25 liters) of milk or 1 handful of cooked spinach is 1 serving. People who cannot digest milk should be sure to eat the equivalent vegetables. Teenagers need 3 servings from this group each day.

Good food sources: Milk and foods made from milk, such as yogurt and cheese. Vegetables such as green soybeans, okra, and spinach.

Fruits

Most fruits have many different vitamins that are important to help your body grow and heal itself when you are sick or hurt. They help heal cuts and wounds, keep your teeth and gums healthy, and help protect you against infections. The minerals in fruits help your heart. It is nearly impossible to eat too many fruits. At least 2 servings of fruit each day are best for people of any age. A small, ripe mango is about one serving.

Good food sources/examples: Mangoes, bananas, papaya, tamarind, watermelon and guava.





Grains

Grains are also a good source of energy. The vitamins and minerals found in grains help your blood and help your body release energy from protein, fat and carbohydrates. Some grains have iron, something our blood needs. Teenage youths should try to eat the equivalent of 5 servings of grain each day. About 1 adult-size handful of cooked grain is considered a single serving.

Good food sources: Rice and bread. Even better are foods with whole grains and the additional nutrients they provide; these foods include whole grain cornmeal, millet and sorghum.

Meats

Meat is a source of protein, and protein is a building block for bones, muscles, nerve tissue, skin and blood. Meats are also a source of iron, a mineral essential to hemoglobin. Hemoglobin carries oxygen from our lungs to every cell in our bodies. Girls and women who menstruate are constantly replenishing blood in their system and can become anemic if they don't have enough iron for healthy blood. Girls, younger boys and women need 2 servings of food from this group each day. Older boys and active men need 3 servings. An egg is one serving.

Good food sources: Meats such as beef, chicken, pork; fish; also peanuts, lentils, soybeans and other types of beans.

Vegetables

Like fruits, vegetables have many different nutrients that help our bodies in many ways. Also like fruits, it is difficult to eat too many vegetables. At least 3 servings of vegetables each day are best for all ages. About 1 adult handful of cut up or cooked vegetables is one serving.

Good food sources and specific benefits:

Green beans provide protein as well as other nutrients.

Spinach has iron, which is good for your blood.

Sweet potatoes, yams, carrots, and plantain help your eyes and skin.

Tomatoes, green and red peppers, okra, and cucumbers help heal wounds and help our skin.

Starchy vegetables like cassava, corn, and potatoes help us feel full and help produce energy in our cells, but they are not as nutritious as many other types of vegetables.

SECTION II

Help for Teachers: Bringing the School Garden into the Classroom

A. Introduction to School Gardens

Gardening can be a fun and interesting way to help students learn. Meanwhile, of course gardens and their bounty help to improve food security.

Many factors influence the success and sustainability of a school garden, including good gardening practices. Fortunately, we can learn from the successes and challenges of others around the world, made possible by research conducted by organizations such as the World Food Program and the Food and Agricultural Organization of the United Nations. Meanwhile, experience also tells us that school gardens are more beneficial and sustainable when they are incorporated into the school curriculum and classroom activities.

Sustaining a school garden is just one goal of this project. We also aspire to improve the primary school curriculum to help students succeed in school, in their community, and in life. This section of the Manual integrates experiential (child-centered) learning methods to bring the school garden into the classroom. We present materials and activities that include ideas for managing and improving the school gardens, and offer recommendations for classroom lessons aimed at helping students learn across the curriculum.

School gardens have many benefits – and not just for the students who work in them and those that enjoy the food produced. When students learn new gardening techniques, they can pass them on to their parents and households. Communities benefit in turn when their citizens work together to support the garden, and community members can learn new gardening techniques. Local organizations and school gardens can enhance and complement each others' programs in nutrition and health, income generation, and other social programs.

1. Major Aims of School Garden Programs

Educational Aims

- Increase the relevance and quality of education for rural and urban children by introducing into the curricula important life skills.
- Teach students how to establish and maintain home gardens and encourage the production and consumption of micronutrient-rich fruits and vegetables.
- Provide active learning by linking gardens with other subjects.
- Increase access to education by attracting children and their families to a school that addresses topics relevant to their lives.
- Improve children's attitudes towards agriculture and rural life.
- Teach environmental issues, including how to grow safe food without synthetic fertilizers and pesticides.
- Teach practical nutrition education in order to promote healthy diets and lifestyles.
- Provide students with a tool for survival at times of food shortages.

Economic and Food Security Aims

- Familiarize school children with sustainable production of food, especially methods that are applicable to their homestead or farm and important for household food security.
- Improve food availability and diversity.
- Enhance the nutritional quality of school meals.
- Reduce the incidence of malnourished school children.
- Increase school attendance and compensate for the loss in transfer of "life skills" from parents to children – especially in child-headed households.
- Promote income-generation opportunities.

Source: Special Programme for Food Security Doc 31, School Gardens Concept Paper, Food and Agriculture Organization of the United Nations (FAO), September 2004.

2. Major Benefits of School Gardens

Students and communities can learn many things from school gardens.

Intellectual Development – Academic Skills

- Support core academic training, particularly in science and mathematics – real world hands-on experiences.
- Enrich core curriculum in language arts through the introduction of new learning topics.
- Learn about the environment and promote sustainable development.
- Learn scientific methods.

Psychological Development – Social and Moral Skills

- Develop responsibility.
- Learn the joy and dignity of work – foster work ethic.
- Increase self-esteem and confidence.
- Develop patience.
- Develop a sense of cooperation and school spirit.
- Learn respect for public and private property.

Vocational Development – Life Skills

- Demonstrate basic skills and vocational competencies.
- Produce food and other commodities.
- Make the most of limited resources, including food.
- Engage in community service and environmental care.
- Work with community organizations for mutual benefit.
- Invest in lessons of leadership and decision making.
- Transfer to household the skills learned in school.

Physical Development

- Provide nutritious food for students.
- Reinforce public and personal health concepts.



3. Core Beliefs and Convictions of School Garden Projects

Most teachers and school administrators at schools with gardens agree that school gardens have many benefits and purposes. At the same time, the primary purpose of the garden and how it will function may vary from school to school, in part because of historical, cultural, and community differences. Before you take steps to establish a school garden it is important to explore the various beliefs, values and convictions which you and members of your school Garden Committee may have.

In many cases, school gardens are partially sponsored by aid agencies. That means the sponsoring organization may have specific requirements of or intents for the school gardens. Be sure you understand these as you discuss some core beliefs about the purposes for your garden or how it will operate.

The following chart offers a range of possible beliefs or guidelines about school gardens. There is no right or wrong list of beliefs, and some of these statements may actually contradict each other. Use a pencil to check the beliefs you think are true for your school. You may want to discuss this with your school Garden Committee.

The garden can be integrated into animal husbandry projects. Non-governmental organizations can provide school garden expertise and resources.



Guidelines For Our School Garden

- The primary purpose of the school garden is to produce food for students to eat at school.
- The garden is a way to address food security concerns.
- The garden should be used as a laboratory to help support lessons in geography, math, science, social studies, languages and music.
- The garden is one tool that can help students expand their academic, vocational and social skills.
- Students of all ages and abilities can contribute to and learn from the garden.
- All students will work and learn in the garden.
- The garden will not be used as a reward or as a punishment.
- The garden will be planned and managed by a team composed of community and school leaders and students.
- The produce from the garden can be sold to generate income for the school.
- Garden labor will come from students, teachers, and persons hired to cultivate and tend it.
- We will have a school garden only if we find time and local interest.
- Other _____
- Other _____

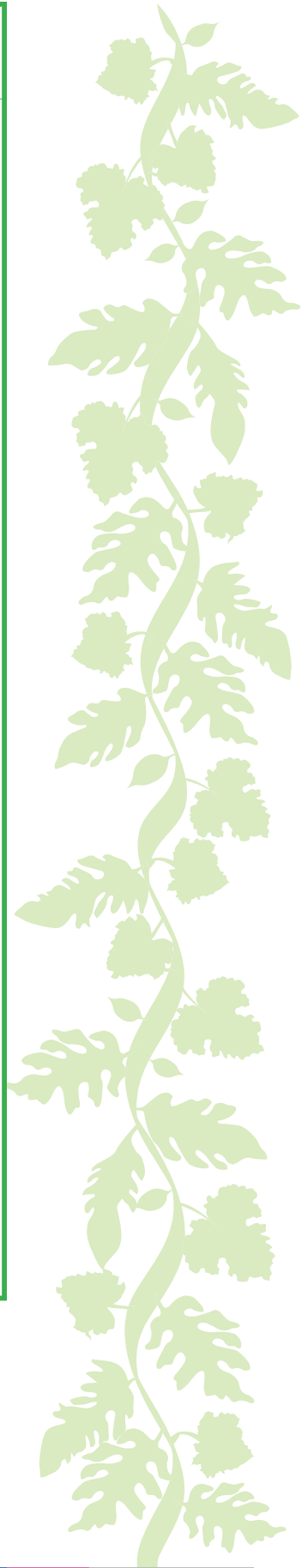

4. Elements Necessary for a School Garden Program

Lessons learned from past experience around the world tell us there are key elements necessary for building and sustaining school gardens.

This figure summarizes the main policy and strategic elements required for a successful school garden.

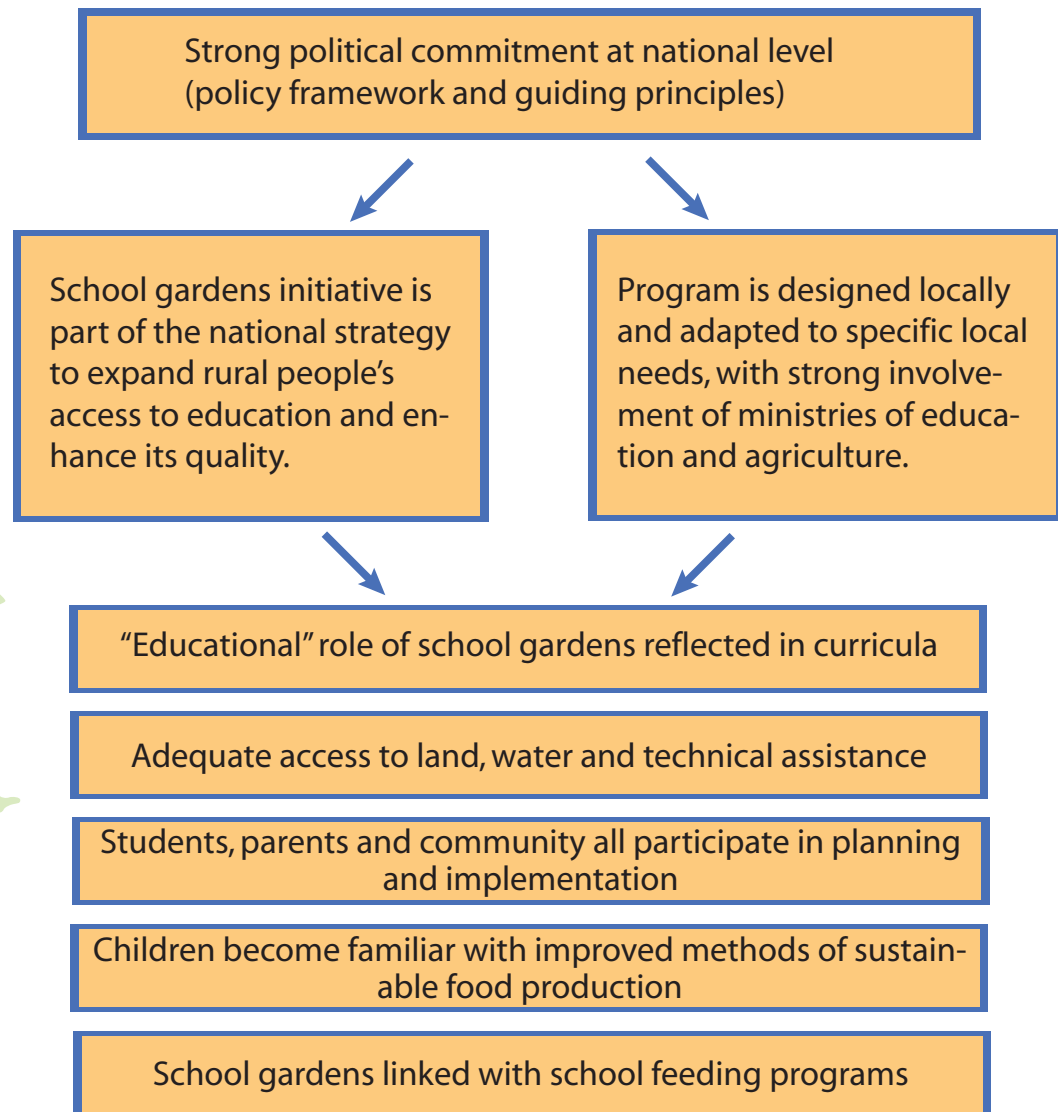

Source: School Gardens Concept Paper, Special Programme for Food Security. Document #31, Food and Agriculture Organization of the United Nations (FAO), Rome, Italy. (2004).

B. Involving the Community in Garden Management

Experience tells us that to be able to develop and sustain a school garden, there is much work to do from sociological and scientific perspectives alike. Good management is critical to the success of the garden.

The more people you have involved in the Garden Committee, the more support you will have for the garden.

The previous pages outline some of the benefits and key elements of a school garden. All of these need to be considered. While the technical aspects of growing a garden are the same whether for a household or a school, there are many more factors that influence the success of a school garden.

Elsewhere in this Manual we outline some of the benefits and key elements of a school garden.

1. Create a Garden Management Committee

Both a benefit of and a challenge to a school garden is the number of people who have a stake or an interest in it. This combination of individuals and organizations includes the following:

- Local government officials
- Agriculture experts
- Farmers
- School administrators
- Teachers
- Students
- Parents
- School committee
- Community members
- Influential community members
- Business leaders
- Church or religious leaders
- Sponsoring aid organizations
- Other: _____
- _____



The support of each group is vital; without it starting or maintaining your garden will be more difficult. People are more likely to support a project or activity if they feel they have had an opportunity to contribute to the related decisions and management. Each of these stakeholders will have influence or a perspective that will help improve the school garden.

Gather a potential committee to manage and oversee the school garden. Include people who represent each of the stakeholders listed. Before you agree to have a garden, meet with this committee and discuss some of the tasks and issues involved.

Think about ways that community problems or needs are addressed. Use that as one guide to set up a Garden Committee for your school.

At the first meeting, discuss the following points:

- **Purpose** – Clarify the purpose of the garden. There are many possibilities:
 - to grow food for the students,
 - to grow food to sell to support the school,
 - to provide a laboratory,
 - to supplement the curriculum,
 - to further the social development of the students,
 - to demonstrate to the community
 - other_____.
- **Benefits** – How the garden will benefit the students, the school as a whole, and the community.
- **Community Support** – Think about how the community can help the school garden. Will community members agree that the food grown is for the school children? How will you keep the garden safe?

After discussing some of these issues, determine whether everyone is

Share the News!

Inform persons who could have an interest in using the area, or who may pass through the area with vehicles, animals, etc. about the garden site; this will eliminate the possibility of damage to the site or potential conflicts of interest.

willing to support a school garden and if you should continue to explore any additional issues. If so, take time to consider these issues:

- **Costs** – Tools, seeds, land, etc. What can be donated? What will you need to buy? Will you need to buy things (such as some seeds) in subsequent years to maintain the garden? Who will pay for this?
- **Maintenance** – The students will do some of the garden work when they are at school. Meanwhile, teachers are very busy with their lessons. Are there additional people who can provide overall management and supervision of the garden? Who will do the gardening during school holidays or on weekends? Will parents take turns volunteering? Are there any community members who like to garden and who are willing to volunteer? How will you organize this? Will you hire people or use volunteers?
- **Leadership and Structure** – Who will make decisions about managing the garden? Will it be the Garden Committee? Teachers? School administrator? You may want to select a chairman for the Garden Committee and ask other members to take responsibility for some specific tasks.
- **Site** – Where will you locate the garden? Will the land be donated or lent to you? Is the location politically, religiously, and culturally appropriate for all students and their families? Think about security, access to water, and ways the community can learn from and support your garden.
- **Technical Assistance** – A successful gardening project needs access to technical assistance when it is sought. Identify local experts who can help. This may include people with indigenous knowledge, agricultural professionals, or other persons.
- **Contracts Between Schools and Others** – Some sponsors of school gardens develop agreements or contracts with schools to clarify the responsibilities of donors and stakeholders. Such a document may also list expectations for reporting or the role of the students. You may want to develop an agreement with your school and sponsors. If you do, make sure everyone who is addressed in the agreement receives a copy of it.
- **Other issues:** _____

Summary





There is no one correct way to manage your garden. Still, you must make sure you have leadership from people who represent all of the interested persons involved, and you must communicate progress and effects of the school garden to the people you represent.

After you discuss and make decisions about these issues, determine how your Garden Committee will function. This may include how often you will meet, how any money will be handled, how long members will serve on the Garden Committee, and so on. Will you decide that individuals should retire from the committee after one or two years? Will the retirees be expected to ask others to join the committee?

Share your management plan with the rest of the teachers, the parents' committee, and other groups who will be interested. Be transparent in your management. This transparency will increase the support you receive from the community, students, and parents, which in turn will improve the likelihood of a productive and successful garden.

Good luck! You have a big responsibility that will influence the education and health of many boys and girls!

2. Build Community Support and Involvement with Open Door Events

A wonderful way to gain community support for your garden is to foster ways for community members – in addition to the students – to learn and benefit from it. Teachers and students enjoy learning about new and productive gardening techniques, and so do community members. Instead of merely telling parents or neighbors about the garden, or letting them observe as they pass by, plan some events and take advantage of opportunities to invite them into the garden.

An Open Door event is an excellent way to reach out to parents and

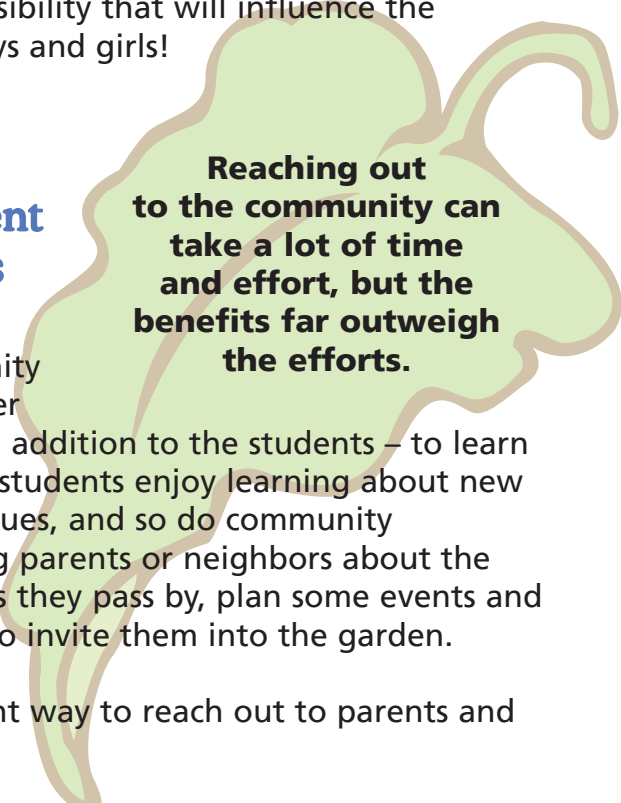

**Reaching out
to the community can
take a lot of time
and effort, but the
benefits far outweigh
the efforts.**

the community.

Community Open Door events are popular around the world as opportunities to show new agricultural techniques. These events also help develop community support for the school garden because they permit others to see the garden firsthand and to benefit from it directly by learning new agricultural techniques.

There are many, many different ways to organize an Open Door event. Here are steps or suggestions. Choose those activities that are most practical for and beneficial to your community.

a. Steps to Planning an Open Door Event

1. Establish a Planning Committee

Set up an Open Door planning committee. Start planning early. These events can be a lot of work and it is usually best to involve many people. Students should also be involved in planning and implementing the event...After all, it is their garden!

2. Determine Goals

The Open Door event might incorporate any or all of these goals, and can provide an opportunity:

- for students to show off their work
- to demonstrate food production techniques
- to provide aid or partner agencies with an opportunity to describe their programs, especially as they may relate to gardening, farming, nutrition, or health
- to recognize and perhaps reward gardening efforts.

3. Choose a Date

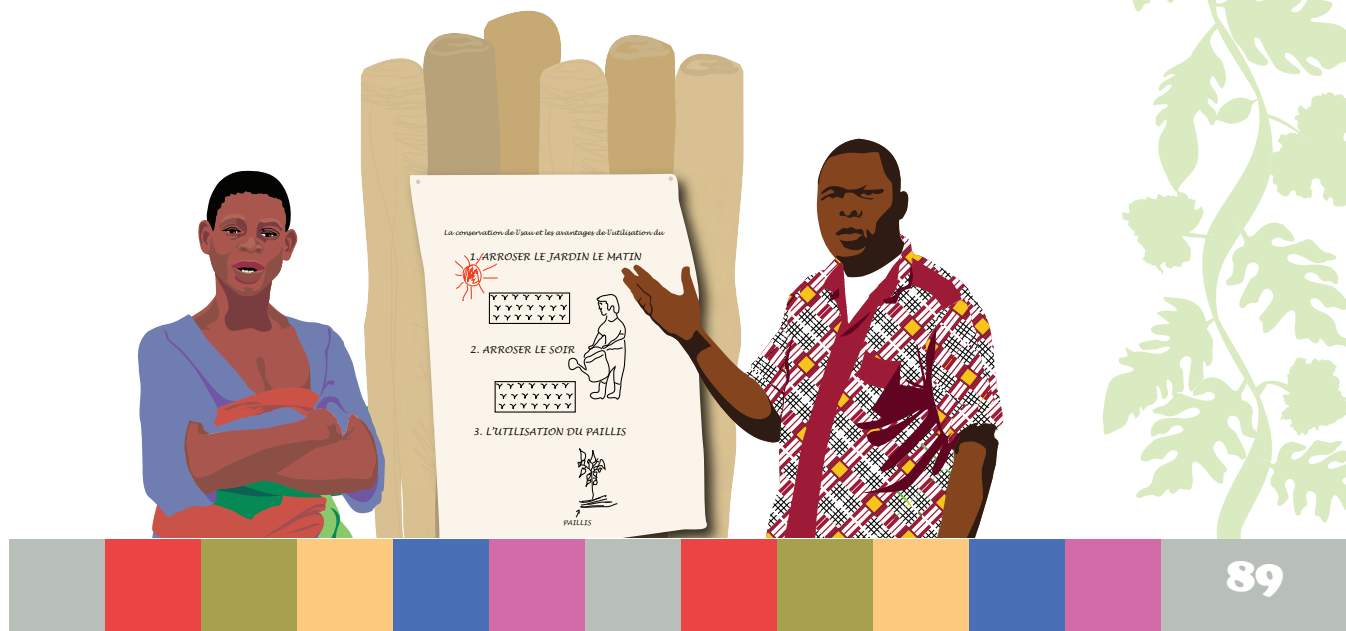



Choose a date that best shows off the garden and is one when many community members might be able to come. Consider the school schedule, too.

4. Promote

Advertise or promote the event with a variety of culturally appropriate methods. Keep in mind the fact that some people cannot read. Invite local dignitaries. This will attract more people and publicity and help promote the event. Be sure students know to invite their parents and neighbors, etc.

5. Determine How

How will you "teach" those who come to the Open Door event? Short demonstrations – both ongoing or at set times – are good teaching methods. Some people may want to talk one-on-one with an expert or have their gardening questions answered. Others may be simply curious; perhaps they like to observe experiments or look at a new variety of a fruit or vegetable in the garden. Finally, dramatic and entertaining presentations will engage students and community alike. The *Planning Guide Worksheet* and ideas for posters which follow will help you organize some of the tasks required for the Open Door event.

6. Determine Who

Who will do what? Who will teach? Who will greet visitors? Who will answer questions, etc.? Be sure to invite local experts as part of your Open Door team, and that they come with a wide variety of expertise. Trained individuals from some aid organizations will be eager to share their knowledge and skills. Students can teach by demonstrating how they set up experiments and explaining what they learned as a result.

7. Invite Partners

Invite various public agencies, non-governmental and/or aid organizations to set up displays or kiosks to promote their programs that are relevant to the school garden, girls' education, public health and nutrition, and many other issues. These organizations will vary from community to community.

8. Involve the Community

Designate a regular time when community members and parents can visit the garden. For example, 3-5 PM on the third Thursday of each month in which school is in session. Post a sign with this information near the garden so people will know this is an ongoing opportunity.

9. Involve Students

As detailed later, by having students help prepare for and host an Open Door event, you help them enhance some of the many life skills that gardening helps to teach.

10. Evaluate

After the event, spend some time discussing what went well and what you might do differently the next time.

11. Congratulate

Congratulate each other. Celebrate your success!

b. Involve Students in Open Door Events

It takes a lot of people to host a successful Open Door event. Fortunately, you have the Garden Committee and students to help out. Take time to carefully consider ways to involve the students as promoters, hosts, teachers, and more.

As mentioned above, while working in gardens teaches students important life skills, when students help prepare for and host the open door events, these skills are enhanced and enriched even further.





Skills students develop include the following:

- Communication skills
- Management and organization skills
- Agricultural and vocational skills
- Leadership and cooperation skills
- Academic competencies

Students can benefit by participating in many ways:

1. Promote

Students should help promote the Open Door event. They should start by telling news of the upcoming event to their own family or household and continue to spread the word among the households nearby. It is good if people hear of the Open Door event more than once, even a number of times.

2. Host

A few older or advanced students should monitor different parts of the garden. They should be ready to answer questions or explain some of the technology, an experiment, or some of the ways in which they used the garden in their classroom.

3. Make Signs

Students should make signs explaining some of the experiments, detailing results and/or directions that others may try in their home gardens.

4. Assign Student Roles

Make the Open Door event a type of "assignment" for the students. They will learn oral and written communication skills as well as more about the techniques they are explaining. Rotate the responsibilities so each student or group of students has an opportunity throughout the day. Those students who cannot host an Open Door station can contribute by preparing materials ahead of time.

5. Introduce Parents

Parents may make a special effort to come to an Open Door event when their child is a host. Teachers or members of the Garden Committee should make an effort to meet the parents and express appreciation for their support of their child's education.

c. Share Responsibility for an Open Door Event

When you plan an Open Door event, think of the many tasks that need to be managed. Make a list and assign or ask people to be responsible for some of the tasks. Students, other teachers, local experts, and the Garden Committee are all potential helpers. Here are some examples of tasks. Some are optional.



School Garden Open Door Event <i>List of Tasks</i>	Person(s) Responsible
Coordinate promotion	
Invite and host dignitaries and local officials.	
Organize stations/places in the garden for each lesson or demonstration.	
Coordinate lessons or demonstrations.	
Lesson 1	
Lesson 2	
Lesson 3	
Lesson 4	
Etc.	
Make informational signs and posters.	
Greet people at the gate/door.	
Manage traffic flow.	
Greet and visit with parents. (The Director, head teacher, and/or teachers may want to do this.)	
Have students sing and dance for guests.	
Supervise students who are helping.	
Gather feedback from guests.	
Say good-bye, thank people for coming.	
Other _____	

d. Demonstrate Lessons, Experiments or Practices at an Open Door Event

Managing and conducting an Open Door event takes many hands. You will probably need to delegate demonstrations, lessons and other activities to other people or teams of people. These could be other teachers, the Garden Committee, parents or students.

Some people may need a little help organizing all the tasks assigned to them. The Lesson Planning Guide and Planning Guide Worksheet which follows are presented to help you think about some of the event's components and how their related assignments will be carried out.



School Garden Open Door Event
Sample Demonstration / Lesson Planning Guide

Activity/Lesson:	Soil preparation demonstration.
Purpose/Goal:	Illustrate three major steps in preparing soil before planting.
Person in charge:	Jean Pierre
Persons assisting:	Andre, Brigitte, Gabriella
Time being presented:	Entire day, at 15 minute intervals.
Location being presented:	Southwest corner of garden next to compost pits.
Supplies needed:	<ul style="list-style-type: none"> ● hoe, rake, shovel, ● two 1 meter x 1 meter garden beds, ● 1 wheelbarrow of compost ● sign with directions and ingredients, ● green bean seeds

Steps: (What you will say and do...)

Before the demonstration/lesson:

1. Make informational poster with advantages of good soil preparation, how much compost to add.
2. Prepare 1 bed with finished product.
3. Turn up half the soil in the first bed; use this to mix in composting.

During the demonstration/lesson:

1. Explain purpose of good soil preparation. (Improved soil textures, drainage, better germination, better root growth, more nutrients in soil.)
2. Demonstrate how to: remove weeds, turn over soil, add composting, rake smooth.
3. Demonstrate how to sow seeds in well-prepared soil.
4. Ask for questions.

After the demonstration/lesson:

1. Return supplies and tools.
2. Mark seeds planted with stick and label.
3. Remove sign. Save for next Open Door Event.





School Garden Open Door Event
Demonstration / Lesson Planning Guide Worksheet

Activity/Lesson:	
Purpose/Goal:	
Person in charge:	
Persons assisting:	
Time being presented:	
Location being presented:	
Supplies needed:	
Steps: (What you will say and do...)	
Before the demonstration/lesson:	
During the demonstration/lesson:	
After the demonstration/lesson:	

**e. Help People Learn at the Open Door Event:
Use Informational Signs and Posters**

An Open Door is an informal educational event. Participants gain the most from such an event when a variety of visual aids are incorporated. When possible, use real materials to illustrate concepts and for demonstrations. Informational signs and posters also help. They reinforce what the demonstrator might say, provide detail that is difficult to remember, and help people learn on their own in situations when no one is on hand to elaborate.

Here are some ideas for signs or posters you may want to make for an Open Door event:

- Sponsors of the school garden – non-government groups, or Ministry of Agriculture, etc.
- Purposes of the school garden.
- Management of the school garden – Garden Committee members.
- Production – vegetables and fruits grown in the garden. What happens to the produce? (Do students eat it? Is it sold? If sold, how is the money used?)
- Topic of each demonstration or lesson – Composting, Nutrition, Vegetable Varieties, Soil Preparation, Natural Insecticides, Natural Fungicides, Water Conservation/Mulching, Transplanting Seedlings, Testing Seeds for Germination, etc.

For each demonstration or lesson, make a poster that includes the following:

- Title of experiment or method
- Purpose
- Simple steps or directions
- How to apply or use in the garden

The poster style is important, too:

- Make your posters on newsprint or a large piece of paper.
- With a marker, use block printing, not cursive. People who do not read well cannot read cursive.
- Use drawings whenever possible to further explain measurements and directions. Illustrations help people remember better – especially those who do not read well.

Sample Poster for an Open Door Event

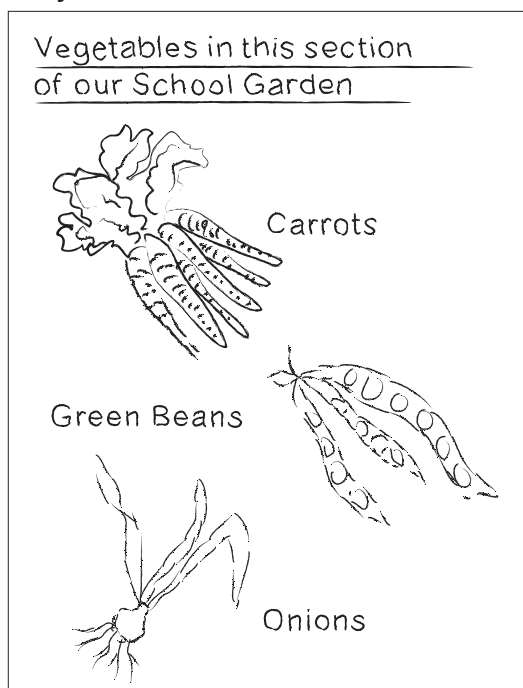

C. Experiential Learning Methods and Theory

When we use learning methods that involve experiences such as hearing, saying and doing, it is called *Experiential Learning*. This section first reviews some theory of experiential learning, several activities and suggestions follow to help you incorporate experiential learning in your classroom.

Think about a learning experience that was especially valuable for you, as the learner/student. How was the event structured or managed that made it a good experience?

Think about a learning experience that was not productive or beneficial for you as the learner/student. Compare the structure and characteristics of the event with the positive event you just reviewed.

In the positive learning experience you were probably highly involved or engaged in the lesson. The lesson was probably focused on you, rather than on the teacher and his/her expertise. The key concept here is how we learn, because how we learn information directly influences whether we remember or retain the concepts taught.

The chart that follows tells us that the more we involve the students and their senses in the learning process, the more likely they are to remember or retain the information or skills being taught.



Teaching Methods Influence Learning		
Teaching Methods <i>When teachers use...</i>	Learning Methods <i>When students...</i>	Retention Rate <i>Students remember...</i>
Lecture, Radio	Hear	10%
Leaflet, Textbook	Read	20%
Display, Video	See	30%
Drama, Demonstration, Film	Hear and See	50%
Discussion	Say	80%
Simulation, Practice, Laboratory, Game	Do	90%

What learning methods do you usually use in the classroom?

What are the implications of this for your students?



1. The Experiential Learning Cycle

Learning is more than a student taking in information or participating in an activity. That is just one step in many. The learning cycle requires the learner to progress through three different phases so that information can be retained and used – immediately and in the future. When we have learned effectively we are able to apply the principles we have learned to new situations.

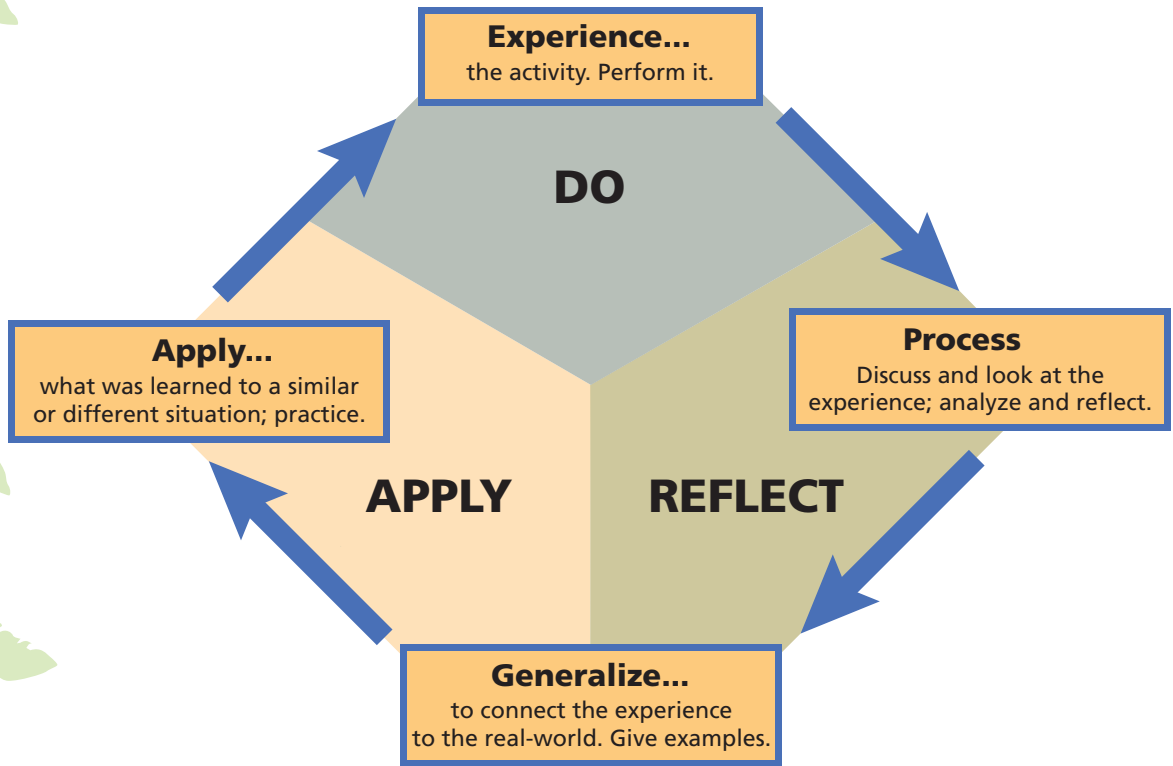

What are the implications of experiential learning for you as learners in this training?

What are the implications of experiential learning for the students when you are teaching gardening concepts?

2. Demonstration Methods

As mentioned in the beginning of this section, when students hear and see something, they remember 50%. In addition, students of all ages usually learn best by doing. Science provides endless opportunities to demonstrate how theory is applied. Some demonstrations are exact replicas of a process, while others are simulations when the real thing is not practical. We are not able to see or visualize some scientific theories, so demonstrations are essential.

A first step to understand a process or to develop a skill is to see it demonstrated – presented and explained at the same time. Teachers and students alike should strive to master demonstration skills.

Uses

- To teach a specific skill or technique.
- To model a step-by-step approach.

Advantages

- Easy to focus learner's attention.
- Shows practical applications of a method.
- Involves learners when they try the method themselves.
- Involves many of the learner's senses, which helps them learn and remember more.

Things to be aware of before you decide to use a demonstration

- Requires planning and practice ahead of time.
- Requires having adequate materials on hand for everyone who will participate (if applicable).
- Requires providing feedback to learners when they try on their own.



Process

- Introduce the demonstration: What is the purpose?
- Present the material you are going to use.
- Demonstrate.
- Demonstrate again, explaining each step.
- Invite the students to ask questions.
- Have the students practice on their own. This will increase retention to about 90%.
- Discuss how easy/difficult it was for them: summarize.
- Innovation: Incorporate students' ideas to improve the demonstration.

Tips

- Arrange the learning space and students so everyone can see.
- Face the students as much as possible.
- Have all your materials ready and in one place.
- Ask some of the students to assist with the preparation and/or demonstration.

What are some things you might demonstrate in your school garden or classroom?

Source: Training Trainers for Development, The Centre for Development and Population Activities, Washington, DC, U.S.A. (1995).

3. Classroom Aids

Science and math concepts come alive when you use the garden to demonstrate or reinforce what is in your textbooks. Some textbooks assume you have access to laboratory equipment; whether or not this is the case, keep in mind that you and the students can make your own scientific equipment.

A little creativity and resourcefulness is all you need to stock your own laboratory. You can use existing things from your natural environment (plants, insects, water, etc.) or make many simple devices that are locally available and free for demonstrating scientific concepts. Look around you. Collect discarded or free things you can use to demonstrate scientific or mathematical concepts. This might include the following items:

Items Useful for Demonstrating Scientific or Mathematical Concepts	
insects large food tins metal cans old newspapers plants sticks, long and straight stones string	plastic bottles (1 liter or other sizes) plastic bowls, trays and cups (various sizes) other: _____ _____ _____

The above items are used in the Classroom Lessons found later in this Manual.

The next few pages present Classroom Activities. First are directions for making two items that are important in studies with gardening and science: rain gauges and measuring tapes. Following these are two Classroom Activities that can be used for many disciplines: writing and performing songs, and writing and performing dramas.





CLASSROOM ACTIVITY: Make a Rain Gauge

We can tell if the garden needs rain with our own eyes and judgment. But collecting and measuring rain in a gauge can provide countless ways to involve students in scientific inquiry. You can use rain gauges and the data you collect from them in many lessons or experiments.

By making your own rain gauges your supply will be plentiful; this means you can set out several in the garden for many students to see and use at one time. Meanwhile, these rain gauges will remove the worry about the possibility of a commercial rain gauge being broken or stolen.

To make a rain gauge:

Collect these materials

- The school's commercial rain gauge. (Note: store it in a secure place after you have finished this exercise.)
- A discarded clear or transparent, 1-liter plastic bottle (cap and label removed).
- A waterproof/permanent marking pen.
- A knife or scissors to cut the bottle.
- A pan or small bucket of water.

Complete these steps

1. Cut the top off of the bottle so it is about half the original size.
2. Pour exactly a depth of 1 cm. water into the commercial rain gauge.
3. Pour the water from the rain gauge into the bottom of the bottle. Mark a line on the bottle at the top of the water and write "1 cm." next to the line.
4. Repeat steps 2 and 3, 1 cm. at a time until you reach the top of the bottle. As you add each centimeter of water, add 1 cm. to the amount you mark on the bottle (2 cm., 3 cm., 4 cm., etc.).

Use the commercial rain gauge to calibrate your handmade gauge. Note that it is necessary to mark the bottle after you pour an accurate amount of water into it because the bottom and sides of the bottle may not be flat or the bottle width may vary.

To use a rain gauge:

- Attach it to a bamboo stake with string or tape. Place the stake in the ground away from trees, buildings or fences so that the rainfall above it will not be obstructed. Make sure the gauge itself is at eye level so students can read it easily.
- Collect data from the rain gauge for use in experiments or teaching. Refer to the Classroom Lessons in this Manual for several ideas.
- Use the rain gauges or similar devices in your classroom to measure liquids in experiments or in demonstrations of scientific principles.





CLASSROOM ACTIVITY: Make a Measuring Tape

Gardens provide many opportunities for students to learn and apply theories in measuring. Each classroom or group of students can make their own measuring instrument out of inexpensive rope or string.

To make a measuring tape:

Collect these materials

- A meter stick. (Note: store it in a secure place after you have finished this exercise.)
- A length of string or lightweight rope or cord – at least 3 meters long. (Note: Nylon cord is durable but can stretch and is difficult to mark.)
- A waterproof/permanent marker.
- A knife or scissors to cut the string.

Complete these steps

1. Tie a knot very near the end of the rope.
2. Place the knot at the end of the meter stick. Hold the rope taut along the stick and measure 1 meter length.
3. Move the mark to the beginning of the meter stick and mark off another meter.
4. Repeat this process until you have marked 3 or 4 meters.
5. Cut the rope at the 4 meter mark PLUS enough to make another knot at the end of the rope. Try to place the knot so that it is exactly at a full meter.
6. Using the meter stick and marker, mark the rope at every 10 centimeters.

Instead of indicating meters with a marker, you may tie a knot in the rope at each meter. If you use this method you will need a little extra rope to accommodate that taken up by the knot.

CLASSROOM ACTIVITY: Write and Present a Song (Performance Arts)

Songs are a powerful way to transmit our culture from one generation to the next. When we sing we use different skills and we can express ourselves in ways that reflect our culture. Many teachers use music and songs in school to help students remember important lessons while entertaining them at the same time. Meanwhile, songs also help to reinforce knowledge and attitudes about the school garden. Finally, writing and performing songs helps boost self-confidence and poise.

Use songs for an entertaining way to teach during a garden Open Door event.

A good song for students is simple and easy to remember, repeats important concepts, and has a melody that everyone can sing.

Write a song about your school garden that you can teach the students. Or have the students write songs. Provide some guidelines:

1. All students in the group must be involved in some way.
2. List the specific gardening concepts that should be presented in the song. For example:
 - coming to school every day
 - cooperation and working together
 - appreciating nature
 - contributing to the garden
 - being respectful of the plants in the garden
 - keeping the garden secure
 - washing hands
 - nutrition and eating food grown in the garden

The songs can include actions for the students. For example, include gestures that simulate planting, the sun or rain, cooperation, etc. Because the students will be using more of their senses when they incorporate actions into songs this way, they will remember the concepts presented even more.

3. Present the song to the rest of the class. Be respectful of each group when they are presenting their song.

After each presentation, review and discuss the lessons learned from the song.

Several activities presented later in this Manual actively use music to teach. Refer to Classroom Lessons: *Write a Song and Teaching Garden Skills Through Dance and Music*.

CLASSROOM ACTIVITY: Write and Present a Drama (Performance Arts)

Dramas help students apply and reinforce some of the technical skills they learn in the garden and help them sharpen their proficiencies in social studies, language, mathematics, geography, and science – all at the same time and in a fun way.

Most children enjoy dramas. Like singing, with dramas students are free to use many of their senses; this means they will remember more of the concepts presented.

With dramas, students can develop their creativity, talents they cannot otherwise demonstrate in the traditional classroom, and they can explore and express their attitudes about concepts that are otherwise off-limits.

Finally, creating dramas and performing in them helps boost self-confidence and poise.

Have the students work in groups of 20 to develop and act out skits or dramas about the garden. Provide some guidelines:

1. All students in the group must be involved in some way.
2. The drama should be about 5 minutes in length for primary students.
3. List the specific gardening concepts that should be presented in the drama. For example:
 - coming to school every day
 - cooperation and working together
 - appreciating nature
 - contributing to the garden
 - being respectful of the plants in the garden
 - keeping the garden secure
 - washing hands
 - nutrition and eating food grown in the garden
4. Present the drama to the rest of the class. Be respectful of each group when they are presenting their drama.

After each presentation, review and discuss the lessons learned from the drama.

For several ideas on how to use dramas in the classroom, refer to the Classroom Lesson: Rainstorm.

Use dramas for an entertaining way to teach during a garden Open Door event.

4. Involve Students in the Garden

A successful school garden depends on students working in the garden. But it is not feasible to have more than 100 students – or an entire classroom – in the garden at one time. Students can be distracted, trample the plants, throw things, and play with each other. They also need to handle the plants, water, compost and harvest correctly, and to pull only weeds, not plants.

Here are some suggestions for making the most of the students' help and time in the garden.

- Have a very positive and enthusiastic attitude about the garden and be an example of that for the students. Do not use working in the garden as a punishment for students.
- Coordinate garden tasks (and lessons in the garden) with the other teachers in your school so that there will be only one group of students in the garden at a time.
- Make a list of garden "rules" with the students. For example: no eating foods, listen to the teacher in the garden, walk on the paths only, do not step on plants, etc. Post the rules in the classroom. Decide what will happen if the rules are not followed. Because students are more likely to follow rules when they have had a say in them, make sure the students are asked to contribute to the list.





- Before you go to the garden, explain to the students – and if possible demonstrate – what they will do in the garden. Remind them of the rules. Keep in mind that you should provide garden updates throughout the season, telling students what they might see in the garden that is new or things they must avoid.
- Have students help keep records of what they have done in the garden and when they have done it. Keeping a record in this way will help them feel more responsible for the success of the garden.
- Students should work in groups of four or five, or more and should take turns as group leader. The leaders can help monitor the other students in their group. When you are demonstrating something, make sure the group leaders for that day can see and understand the process well so that they can demonstrate it to the others.
- Students who feel a sense of responsibility for the garden will be more likely to cooperate in hard work to make the garden a success. Think of opportunities for students to lead activities, demonstrations, and so on.

What other ideas can you think of to involve students in the school garden?

Friendly Competition

Students often enjoy competition between classmates or with other classes. Discuss with the class and the other teachers how you might design some friendly competition with the other students. Such good-natured competition can be a great incentive to do well in the garden.

Decide what will determine the "winning entry." The best vegetables? The best experiment? The most productive plot? The biggest sweet potato?

Decide what kind of prize the winners will receive. Material prizes may be difficult to determine or obtain, so think of creative ways to reward students. Perhaps the losing team must clean the classroom of the winning team, for example. Again, involve the students; they may offer some innovative ideas for rewards.



Child Labor

Students can learn a lot by working in the garden. But they should not be treated as free labor. Discuss and set a school policy for how often the students will work in the garden.

Do not treat students as if they are free labor: 1 hour/week/student is reasonable.

The World Food Program has determined that 1 hour/week/student is reasonable. Since most schools have many students, this allotment may be substantial for adequately tending the garden. Additional students may volunteer to work more hours as part of a club or for other reasons. The school Garden Committee should set this policy.

Can you think of other ways to involve students in the school garden?



5. Experiment in the Garden and Classroom

What is an Experiment?

Much of our knowledge of science – including agriculture and nutrition – comes from experimentation. An experiment is a test of a hypothesis or prediction; the results of this test help us understand something. The term "experiment" is often used incorrectly. For example, when we try something to see what happens, but lack a second activity to compare our experience, this is not a true experiment. Without comparison we cannot be sure why or how the results came to be.

In an experiment, all variables must be kept the same except one. The design of an experiment is sometimes called protocol.

Why Experiment?

Experimentation is a common and respected way to test a theory or procedure; the results of the experiment help us choose to adapt new practices or to change our behavior. When we do, see, or learn from an experiment, we can solve problems and improve the way we do something. The experiment – and interpreting its results – is a vital tool for agriculture, for science, and for many other disciplines. Experiments have other additional benefits as well:

Experimentation teaches students many skills:

- think critically
- question
- observe
- analyze
- keep records
- apply mathematical theory
- apply scientific theory
- be a better consumer of information

Experiments should apply experiential learning methods.

Therefore students:

- retain more information/knowledge because they learn by doing
- learn according to learning styles that best suit them
- apply experimentation to many facets of their lives
- use experimentation to teach others new gardening practices

The next page illustrates how to set up an experiment about the value of compost. The design of an experiment is sometimes called protocol.

Basic Elements of a Good Experiment

Element	Example
1. A problem or situation that needs to be improved or changed.	1. The problem does not have to be complex. It may be as simple as wanting a plant to grow.
2. <i>Hypothesis.</i> We predict something will or will not happen as a result of a change or intervention. We have to do something to change the current condition.	2. We could hypothesize that watering or adding fertilizer to a plant will increase production. The fertilizer is the variable.
3. <i>Design.</i> We need to set up the experiment so that we can test our hypothesis. This includes how we will apply our intervention and setting up a "control." We cannot be sure why our intervention worked if we do not have something else to compare it to.	3. If we want to see how fertilizer affects a plant, we need to plant some vegetables that we fertilize. We decide how much and how often to apply fertilizer. Next to the fertilized plants we have some plants that we do not fertilize.
4. <i>Observation.</i> We need to observe and then record what we see so that we can analyze what happened.	4. This may entail measuring the fertilized and unfertilized plants every few days, as well as tracking and recording the temperature, the climate, and rainfall amounts.
5. <i>Analysis of data.</i> The data either proves or does not prove your hypothesis.	5. Look at the data you have recorded about the plants. Compare the fertilized plants to the unfertilized plants. Was your prediction about the use of the fertilizer correct?
6. <i>Draw conclusions...</i> and generalize to other situations.	6. Using the data, come to a conclusion about the value of fertilizing your plants. Can you apply this conclusion to other situations—other plant varieties, for example?



EXPERIMENT EXAMPLE: Experiment with Compost How Does Compost Affect Plant Growth?

1. Identify the problem.

Plants need natural fertilizer/compost to grow. You do not know how much compost to apply.

Set up an experiment in which you grow green beans or any other vegetable for at least five weeks, using three methods:

- a lot of compost at one time
- a little compost often
- no compost

2. Develop a hypothesis.

What do you predict will happen?

(e.g. The plants with the most compost applied all at once will grow most quickly and produce the most fruit.)

3. Design your experiment.

Plant 12 seedlings. Divide into three groups of four plants each – A, B, and C. Make sure all the plants are in one shared location.

- Group A – add 5 cm. of compost at planting
- Group B – add 1 cm. of compost each week for 5 weeks
- Group C – do not compost

Post signs on sticks so you and the students will know how each group was treated.

For example:

- Compost once at planting
- Compost frequently
- No compost

Water each group the same.

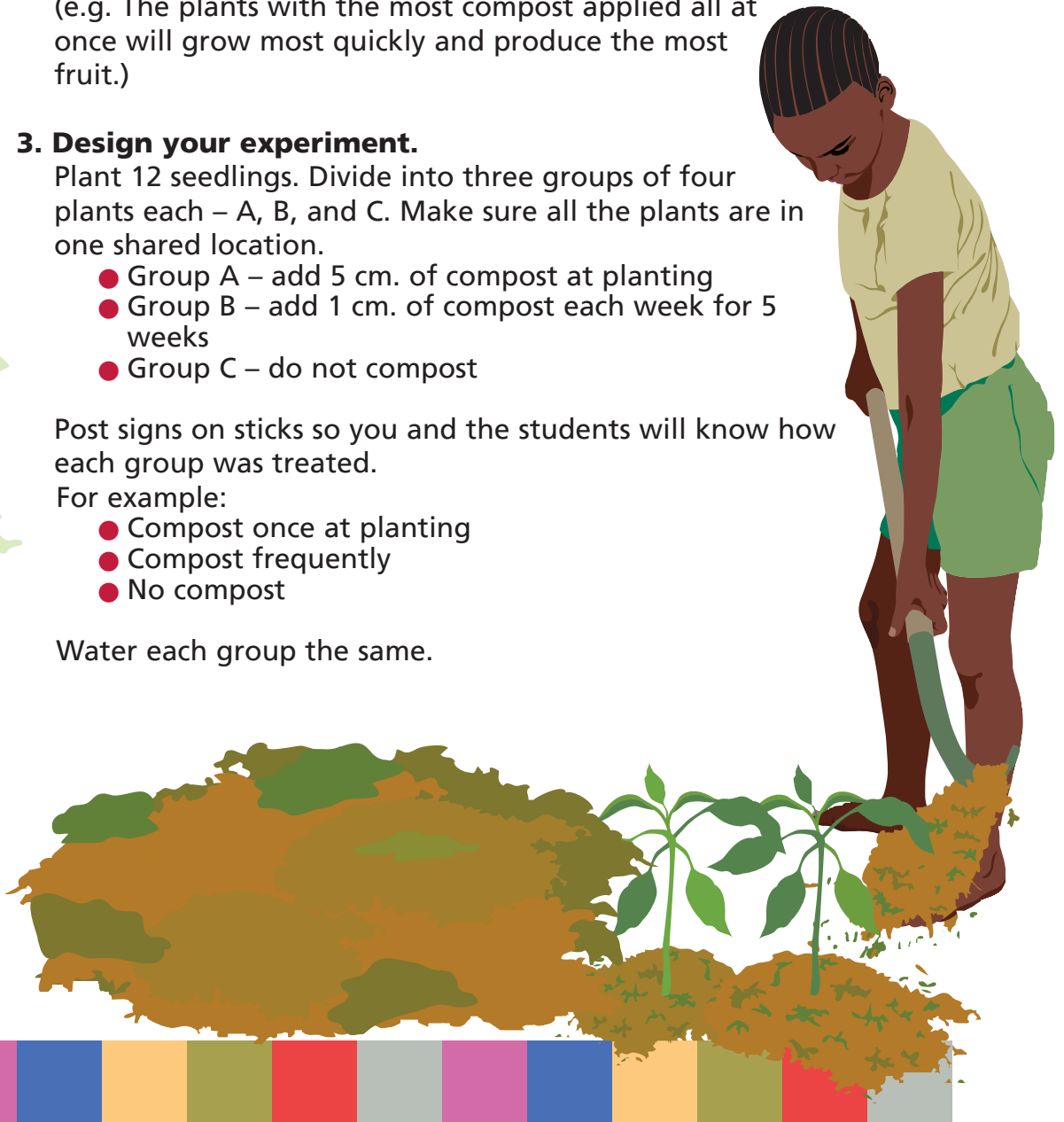

4. Observe all of the groups.

Observe all groups for an equal length of time or until the plants are ready for harvesting. Once a week, measure the plants in each group and make a chart like the one here for recording the data. Calculate the average height of the plants in each group. If you continue the experiment until you harvest, count or weigh how much you harvest from each of the groups. Also observe and record any differences in quality.

5. Analyze the data.

At the end of the experiment, compare the growth of the plants in each group.

- Which group grew the best?
- How did the amount of composting influence the growth of the plants in that group?
- Based on the data from your observations, did you prove your hypothesis?
- Why or why not?

6. Draw conclusions and generalizations.

- What can you conclude about the use of composting in growing this plant?
- Is it better to use a lot of compost all at once? What about a little compost more frequently? None at all? Why?
- Would this practice apply to other plants?
- How does composting benefit plants? What is in compost that helps plants grow?
- What is in compost that makes more frequent application better?
- Can you trust the results of your experiment? Could it be improved? Should it be repeated?
- Are 12 plants a large enough sample?





Experiment with Compost Observations Chart												
	Group A <i>5 cm. of compost added at planting</i>				Group B <i>1 cm. of compost added each week for 5 weeks</i>				Group C <i>no compost at any time</i>			
	Plant Height				Plant Height				Plant Height			
	A-1	A-2	A-3	A-4	B-1	B-2	B-3	B-4	C-1	C-2	C-3	C-4
Week 1												
average												
Week 2												
average												
Week 3												
average												
Week 4												
average												
Week 5												
average												
Etc. = Expand table (to include Week 6 until date of harvest.)												
Height at harvest												
Average height at harvest												
Total for produce at harvest												
Average for produce at harvest												
Quality of produce at harvest												



MORE EXPERIMENT IDEAS

Experiment with Compost What Makes Good Compost?

- What are the best conditions for making compost?
- What kinds of organisms are in the compost? Do they remain the same during the process?
- Does all compost decompose at the same rate?
- What kind of liquid compost works the best?

For a specific lesson on compost, refer to Classroom Lesson: *Soil and Organic Matter Experiment*.

Experiment with Light How do Plants Respond to Light?

- How much light do plants need to be healthy?
- Are all plants the same?



6. Use Observation Skills

Seeing and recording the garden environment are critical elements in experiments and science. Therefore, when using the school garden as a teaching tool it is important to include student observations. Some students are naturally observant and notice many things they see, hear, smell, or feel around them. Others are not so observant and need help developing their observation skills.

A second part of observation skills is describing what we see, hear, smell or feel. Some students will be good at describing their observations, others will need help. Observation skills are important in science and mathematics, as well as in other concepts. Good observers use all of their senses and, therefore, are more actively involved in learning. That means they are more likely to remember concepts. It is a type of experiential learning.

At the beginning of the school year try the *Observing, Comparing and Describing* activity (on the following two pages) to help students develop their observation skills. The game teaches students how to describe something by discussing its properties. This may include size, shape, texture, color, and weight.

This activity works well when accompanied by the Classroom Lesson entitled *How Would You Describe It?*



CLASSROOM ACTIVITY: Observing, Comparing and Describing PART 1: Describe an Object

Do this before *Ten Questions* (next page).

Objectives:

- Students will understand that all matter has properties that can be observed, defined, and recorded.
- Students will observe, compare, and describe the structure of various objects.

Materials:

- large box or opaque plastic, paper bag, or cloth
- two objects for students to describe
- a collection of objects for students to describe, which might include a bowl, book, fruit or vegetable, rocks, leaves, shoes, cooking utensil, etc.

Introduction:

1. Ask students to name their favorite food. (Make sure it is a food that is familiar to all the students.) Say, "How could you describe, or tell about, your food so that someone else would have a very clear picture of it?"
2. Help students think of words to describe properties, such as size, weight, color, hardness, shape, texture, odor, taste.
3. Explain to students that everything in our known physical world has a structure that can be observed and described.
4. Hold up an object and ask students to notice its parts. Explain that the parts of an object form its structure.
5. Pass the object around the room. Ask the students to think of ways to describe its texture – how it feels. Think of words that describe texture. These might include rough, smooth, hard, soft, furry, etc.
6. Pass the object around the room again and ask students to describe another property, such as weight ("It is as heavy as ..."), size ("It is as big as...") and so on.
7. Test the students' understanding of observing, comparing and describing by playing *Ten Questions* (next page).

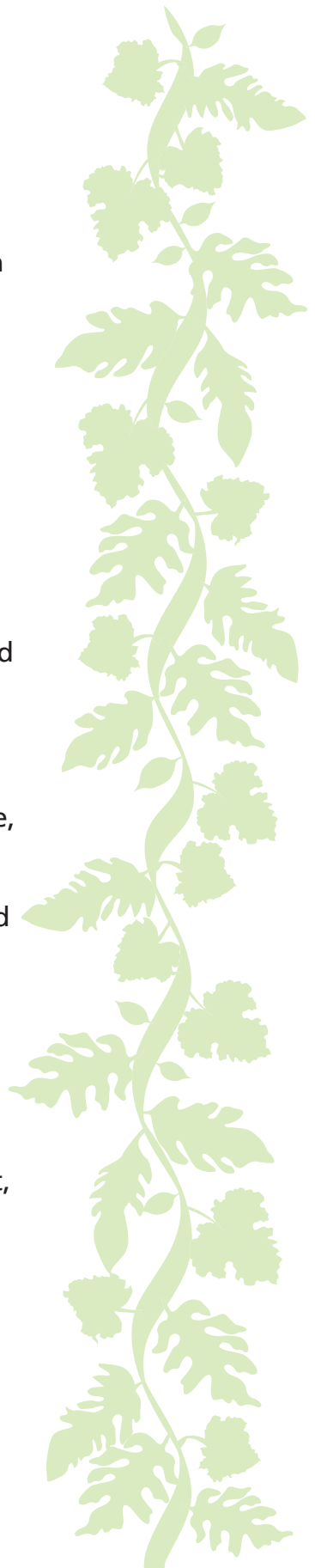



CLASSROOM ACTIVITY: Observing, Comparing and Describing PART 2: Ten Questions

Do this after *Describe an Object* (previous page).

1. Show students the plastic or paper bag.
Tell them that you will place one of the two objects in the bag and hide the other. (You must hide the second object so students cannot guess the object in the bag by the process of simple elimination.) Students will try to guess which object is in the bag.
2. Explain the rules:
 - Guesses must be stated in the form of questions.
 - The teacher may answer only "yes" or "no" to each question.
 - Students may not ask the name of the object. For example, they may not ask, "Is it a pencil?"
 - Questions should be about the object's size, weight, color, shape, or texture. For example, students may ask, "Is it yellow?" or "Is it as big as my foot?"
 - Students who think they know what is hidden in the bag should keep their guesses to themselves until all 10 questions have been asked.
 - After the group has asked 10 questions, remove the object from the bag and show it to everyone.
3. Model how to ask questions.
For example, you might point to your shirt and say, "If I were going to hide this shirt in the bag, I might ask, 'Is it soft?' 'Is it as heavy as a book?' 'Does it have words on it?'" One question not to ask is, "Is it a shirt?" Allow time for students to practice asking suitable questions.
4. Hide an object.
Out of the sight of the students, place one object in the bag and hide the other. Play the game until all 10 questions have been asked. Then have the students guess what is in the bag.
5. Play the game with two new objects.
Pass the objects around and have the students observe them carefully to notice their size, weight, color, shape and texture. Then hide one of the objects and place the other one in the bag and repeat the game.

CLASSROOM ACTIVITY: Observing, Comparing and Describing PART 3: Draw Conclusions

Do this last, after *Describe an Object* and *Ten Questions* (previous pages).

Lead a discussion with the students about what they have learned.

Some sample questions:

- What are some different ways to describe something?
Answer: Texture, size, weight, etc.
- What sorts of questions helped you figure out what was hidden in the bag?
Answer: Questions about the object's properties.
- What do we mean when we talk about structure?
Answer: The parts of an object.
- How will observation skills be used in the garden?
*Answer: Can describe the parts of plants and the environment.
Can observe more closely and accurately.*

Tell the students they will use their skills in observing and describing throughout the year. Journaling is one way to use these skills.

For additional ways to improve student skills in observations and description, refer to Classroom Lesson: *How Would you Describe it?*



CLASSROOM ACTIVITY: Keep a Journal

Journals are records of what happens around us. A newspaper is often called a journal because it records what happens in the community, region or world. Scientists and writers use journals to record what they see, hear, smell, feel and taste. By reviewing what is in the journal, we can have fun remembering what has happened as well as draw some conclusions about something over a long period of time.



Have your students make an individual or class journal about the garden or the environment around the school.

1. Make a "journal" using a notebook, some loose papers, or a piece of flip chart paper. Direct students to use a pencil to write in their journal; because the pencil is waterproof their entries will not wash away if they get wet. Describe how to use the journal.
2. Throughout the season, have the students list things they see, hear, smell, feel, etc., in the garden. Have them list the date, what they observe, and their name. They can do the same thing when they try a new food or activity.
3. You can assign the students with the task of recording things in the journal at certain times or they can do it throughout the year. At particular times they may want to focus on particular things – the weather, the plants, the sun and rain, etc. If you have a year-long journal, you may need to remind them to write in it.
4. During the year or at particular times, review the journal with the students. Have them draw some conclusions or make some observations. For example, are there themes or common observations that appear throughout the year? Are there other things that they have observed only at certain times? Why is this? What kinds of things did they observe? Did writing observations in the journal help them become more observant?

Sample Journal Entry

Class Journal Garden School, Your home town

This journal is a chronicle of our School Gardens activities.

November 10, 2006: Discussed School Gardens concepts and developed a garden management plan.

November 13, 2006: Reviewed needs for school garden and selected site. Garden site is directly south of classroom. Size of garden is to be 10 meters by 20 meters. Site needs to be secured, cleared, planted with Angolan Peas and fenced.



November 14, 2006: Garden site has been cleared by a community member, Mr. Gasana.

November 15, 2006: Garden site partially fenced by Father Semba.

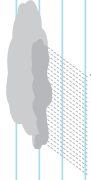

November 18, 2006: Garden completely fenced by Father Semba.

November 20, 2006: Class prepared soil and planted Angolan Peas.

November 22, 2006: Class set up rain gauge.

November 24, 2006: Student (Marika Z.) measured rain, 15mm.

December 5, 2006: Started digging compost in pit.



7. Use Experiential Activities in the Garden

a. Guidelines for Teachers

Remember what you learned about experiential learning? When students learn by doing they remember about 90 percent of what you teach. Teachers in many countries traditionally use a standard curriculum and lecture to the students, rather than adapt or use new teaching methods. Fortunately, the Ministries of Education are very supportive of school gardens as a teaching method.

Rather than trying all of these lessons right away, take time to read them carefully. Which lessons best fit the concepts you have been directed to teach your students? Choose lessons that are appropriate for the level of your students. Work with the Inspector or other teachers if you need a little guidance.

There are endless ways to integrate the school garden into your standard curriculum. Challenge yourself to try one or two classroom lessons each term that include concepts that relate to the garden. Share your ideas with the other teachers. Over time, you will think of more opportunities.

This section of the Manual provides activities to use in teaching. Teachers should take time to become familiar with the contents. While some terms and concepts may be used in ways that are new to you, you can easily adapt them to best fit your classroom.

Instructors should decide what standard course objectives are appropriate for each lesson, and when to teach the lesson.

The following list of Classroom Lessons and their corresponding areas of discipline should help you plan your classroom activities.

b. How to Use the Lesson Recommendations

1. The chart which follows lists dozens of lesson titles in seven different disciplines. The Xs in the grid indicate the disciplines that each lesson listed on the left will address. To find which lessons listed in the first/left column might be useful for you:
 - Locate your discipline(s) at the top of the columns in the chart (e.g. Social Studies).
 - Follow the column down the grid to find Xs.
 - Move across the grid to the left to find the title and page number of lessons that will address your discipline (e.g. Social Studies – lesson title: Rainstorm, page 136).
 - Turn to that page.
You will notice that some lessons can help teach concepts that fit multiple disciplines.
2. Look over the lesson for ideas on how to teach particular concepts. Ask yourself these questions:
 - Are the objectives consistent with what you are trying to teach?
 - Will the proposed activities help students learn more about the concepts or principles you are trying to teach?
 - Are the activities appropriate for the grade level you are teaching? Can you make the lesson simpler or more challenging if necessary?
 - Is this a good time in your curriculum to use this activity?
 - Do you have access to the material listed?

If the answers are “yes”, think about how you will integrate these activities into your lesson plans.
3. Most likely the lesson recommendations are not written or presented in the same format that you use to write your lesson plans. These are only suggestions. Use the Lesson Planning sheet on page 172 to further develop the lesson.
4. After you have tried the new lesson, evaluate yourself and how effective the lesson was. Make notes so that you can repeat your successes and make improvements for the next term or school year when you will teach the lesson again.
5. As you think of new lesson ideas, share them with your fellow teachers. Ask them to do the same. Keep your ideas with this manual so that you and others can benefit.





Recommended Classroom Lessons by Area of Discipline							
Lesson Title	page	Drama, Performance Arts	French, Spelling	Geography	Mathematics, Statistics	Science	Social Studies
How Would You Describe it?	130		●				
Word Search	132		●				
Scrambled Vegetables Game	134		●				
How Do You Spell "Vegetable"?	135		●				
Do Not Fall in the River Vocabulary Game	136		●			●	
Rainstorm	137	●					●
Garden Storytelling	139	●	●				●
Write a Song	140	●	●			●	
How Do Different Surfaces Affect Air Temperature?	141			●		●	
How Does Running Water Change a Landscape?	143			●		●	
How Do Roots Prevent Soil Erosion?	145					●	
Measuring Rainfall	147			●	●	●	●
Geometry in the Garden	150				●		
Which Soil Soaks up More Water?	152			●		●	
What Does the Plant Factory Need?	154					●	
Soil and Organic Matter Experiment	156					●	
Describe an Ecosystem	157		●	●		●	
How Do Plants Reproduce from One Parent?	158					●	
Where Do Plants Store Food?	160					●	
Which Items are Biodegradable?	162			●		●	
Seed Germination Experiment	164				●	●	
Insects in the Garden	166					●	
More Classroom Lessons ● French ● Geography (Map Reading, Map Making) ● Mathematics ● Music ● Science ● Social Studies	168	●	●	●	●	●	●

CLASSROOM LESSON

How Would You Describe It?

Disciplines:

French

(You can do this activity in any language.)

Objectives:

Improve vocabulary

Understand use of adjectives

Improve observation and journal skills

Note: You can make this lesson more simple or difficult to fit the grade level of the students.

Standard Course Objectives:

Month or Unit:

Materials:

Paper and pencil/pen

Proposed Activities:

1. Explain how scientists need to have good observation and journal skills so they can accurately describe and report on their activities.
 - Use an example of something you have already discussed in the classroom that relates to the garden – the soil, the weather, the color of something, etc.
 - Give an example of how a word can be vague: heavy, dense, large. When you use these words, do they help the listener understand what is being described?
Vague words are less helpful than more specific ones.
2. For older students: Review what an adjective is. (An adjective describes a noun or pronoun.)

Categories

Color	Taste
Consistency	Temperature
Shape	Texture
Size	Weight
Smell	

- 
3. Have students list at least five terms to describe each of the prior ways we might describe things we see in the garden.
 4. Have students share their lists with each other. How many adjectives did the class think of for each category?
 5. Discuss the adjectives to make sure each student understands them.
 6. For each category, have students write a sentence using one of the adjectives. Read them to the entire class.
 7. Discuss how their adjectives can be applied to scientific observation and records.

Variations:

1. Use fewer categories.
2. Have students develop additional categories for listing adjectives.
3. Have students write an entire paragraph using an adjective from each category.
4. Have students translate adjectives from one language into another. For example: In French: sol; in English: sunny.
5. Show students something from the garden (a small plant, etc.).

Have students write a paragraph describing the item using vague or broad adjectives. Discuss the accuracy of their report. Have students rewrite the paragraph using more specific adjectives. Discuss the difference and value in the second paragraph.

6. For older students: Give an example of how a word can be vague. For example: heavy, dense, and large. When you use these words, do they help the listener understand what is being described? Vague words are usually not as helpful as more specific terms in understanding science.

Evaluation:

Correct use of vocabulary.
Composition, sentence structure.
Questions asked.
Discussion and participation in the activity.

CLASSROOM LESSON

Word Search

Discipline:

French

Objectives:

Improve vocabulary
Improve word recognition skills
Improve observation skills

Standard Course Objectives:**Month or Unit:****Materials:**

Chalkboard and chalk

Proposed Activities:

1. Make puzzles like the one which follows, using current vocabulary words from the garden. For elementary students, list the words vertically or horizontally. Older students can find words on the diagonal. Or, students can make their own puzzles.
2. Put the puzzle on the chalkboard. List the words they should search for in the puzzle.
3. To play the puzzle, circle the word on the puzzle and mark it off the list when students find it. The first time you use a puzzle like this, circle one word in the puzzle to help the students get started. (Refer to example provided.) Have students take turns coming to the board to circle a word they see. Letters can be used or circled for more than one word.



legumes	fruits	compost	alimentaires
jardinage	sante	vitamine	terre
ecologie	nutrition	frais	graine
arbre	soleil	pluie ✓	nature

g	r	a	i	n	e	c	o	g	l	p	y
p	x	f	h	a	j	o	p	l	u	i	e
o	b	n	r	t	a	m	c	s	a	k	f
v	u	f	t	u	r	p	e	o	s	s	r
i	d	r	e	r	d	o	s	l	t	m	a
t	m	u	n	e	i	s	c	e	e	w	i
a	l	i	m	e	n	t	a	i	r	e	s
m	a	t	u	l	a	i	u	l	r	z	a
i	r	s	q	w	g	t	v	r	e	b	n
n	b	l	a	l	e	g	u	m	e	s	t
e	r	j	d	e	c	o	l	o	g	i	e
g	e	n	u	t	r	i	t	i	o	n	h

Evaluation:

Correct identification of all the vocabulary words.
 Discussion and participation in the activity.

CLASSROOM LESSON

Scrambled Vegetables Game

Discipline:

French

Objectives:

Learn to spell some of the foods grown in the school garden.
Increase vocabulary.

Standard Course Objectives:**Month or Unit:****Materials:**

List of vegetables – scrambled
Vegetable card set
Chalkboard and chalk

Proposed Activities:

1. On the chalkboard, write the list of scrambled words.
2. Draw or hold up a picture of each vegetable. (You can omit this step for older students who need no hint and can unscramble the words without knowing what the choices are. Younger students may need the picture to help them.)
3. Have students unscramble each word to spell it correctly, either orally or in writing. Tell students the pictures may help them.
4. Provide the correct answers.

Evaluation:

Discussion and participation in the activity.

<u>Scrambled:</u>	<u>Correct:</u>
roterca	carrotte
nabane	banana
tadecu pateo	patate douce
hocu	chou
nepadir	epinard
metota	tomate
nopvori	poivron
bienaugre	aubergine
sima	mais
tocirah	haricot
oucger	courge



CLASSROOM LESSON

How Do You Spell “Vegetable”?

Discipline:

French – Level 3/4

Objectives:

Correctly write names of garden vegetables or fruit.
Increase vocabulary
Increase spelling skills

Materials:

Vegetable card set

Proposed Activities/Performance Objectives:

1. Beginning – Check prior knowledge by asking students names of some of the vegetables in the garden.
2. Presentation – Motivate the students by asking them to spell some vegetable names orally.
3. Practice – Show pictures of four vegetables. Write the names of each of the four vegetables on the board. Ask the students to identify and spell the names of the vegetables.
4. Production – Write scrambled names of each of the four vegetables on the board. Show the vegetable cards to the students. Have a student unscramble the vegetable names on the cards and the board. Match each vegetable card with its name and proper spelling.
5. Evaluation – Have the entire class spell the name of each of the four vegetables.
6. Ending – Tell the students they will learn additional vegetables at another time.

This lesson was developed by: Anatole BIKINDOU, Brigitte BOUNGUIENA, Jean Yves MALENGUE, Jean MBOU, Sylvain MOUKIAMA, and Jean Pierre NIATI, Lekoumou District, Republic of . It was the third-place winner in a lesson development competition as part of the School Garden Teacher Training conducted by the U.S. Department of Agriculture, January 2007.

CLASSROOM LESSON

Do Not Fall in the River Vocabulary Game

Disciplines:

French

Science (or other area depending on vocabulary choices)

Objectives:

Improve vocabulary and spelling

Standard Course Objectives:**Month or Unit:****Materials:**

Chalkboards and chalk

Proposed Activities:

Perform the exercise with the entire class, or instead divide the class into smaller groups.

1. Choose a vocabulary word but do not tell the class what the word is. Draw dashes on the board to represent the number of letters in the word.
2. Also on the board, draw a river with a person hanging by his/her hands from a tree limb above the river. The person should be holding on with both hands and the fingers should be clearly visible. (The quality of the drawing is not important.)
3. Ask a student to guess a letter. If the letter is in the word, write it in the correct location(s) on the dash(es). If the letter is not in the word, write it on the board and adjust the drawing so that one of the person's fingers is no longer hanging onto the branch.
4. Continue the game until the person has fallen in the river, or until the word is correctly guessed.

Evaluation:

Discussion and participation in the activity.



CLASSROOM LESSON

Rainstorm

Disciplines:

Drama/Performance Arts
Social Studies

Objectives:

Reinforce the concept of teamwork and cooperation
Improve observation skills

Standard Course Objectives:**Month or Unit:****Materials:**

None

Proposed Activities:

1. Ask for four student volunteers. Assign each one of the following actions and ask them to demonstrate how to do it:
 - Snap fingers
 - Rub palms together
 - Slap hands against thighs
 - Stomp feet on the floor
2. Point out that on their own each volunteer can do only so much with those sounds. Next, tell the class to watch what happens when everyone has a chance to get involved.
3. Divide the group into four sections; assign a volunteer to lead each group. Explain that once you give the group the signal to start, they must keep up the action until you give the signal to stop.
4. Signal the finger snappers to begin. A few seconds later give the signal for the palm rubbers to join in. Wait a few more seconds before signaling the thigh slappers to get started. Finally have the foot stompers begin. (What started out sounding like a gentle rain should by now have turned into quite a storm!)

5. Wait a few seconds and then reverse the action to make the rainstorm subside. Begin by signaling the foot stompers to stop. Then have the thigh slappers stop, followed a few seconds later by the palm rubbers, until all that remains is the gentle sound of fingers snapping.

Evaluation:

What did you learn?

What was the message in this activity?

Answer: It is a good example of what can happen when everyone cooperates and works together.

Using what you learned:

Ask how this relates to working in the garden? In other situations at home or at school?

Answer: Point out that the same thing is true whenever there is work to be done or a problem needs to be solved.



CLASSROOM LESSON

Garden Storytelling

Disciplines:

Drama/Performance Arts
French
Social Studies

Objectives:

Increase language usage
Improve creative and logical thinking
Practice listening and cooperation

Standard Course Objectives:**Month or Unit:****Materials:**

None

Proposed Activities:

1. You or an advanced student should start the story, making sure it has a garden theme.
2. Ask each student to contribute a part to the story orally. Instruct students to listen to the previous parts of the story so they can make a logical contribution.

Example story starters:

- I was walking by the garden as the sun was setting. I heard something...I couldn't quite make out the sound.
- Claudette and Isaac were preparing the garden soil. They were hoeing in the hot sun and sweating and sweating. It felt like they had been digging forever, but they weren't moving very much soil. Claudette said she was really going to break up the dirt. She heaved up the hoe and hit the ground with all her might. A mighty clang sounded as her hoe bounced up into the air.

Alternate Activities:

1. For young students: use this to review the activities they did in the garden that day. Begin with, "Today we worked in the garden. First..."
2. For larger classes: divide the class into smaller groups.
3. This activity is easily adaptable to other themes such as: current local events, cultural events (holidays), school, vacation, and so on.

Evaluation:

Discussion and participation in the activity.

CLASSROOM LESSON

Write a Song

Disciplines:

Drama/Performance Arts
French
Science

Objectives:

Express knowledge of plant needs

Standard Course Objectives:**Month or Unit:****Materials:**

None

Proposed Activities:

1. Have students review what plants need in order to survive and thrive. List them on the chalkboard.
2. Have students create a song about these important items and about taking care of plants. Provide criteria on length or type of song.
3. Have each group present her/his song to the rest of the class. Vote on the best two or three. Have everyone learn the song(s) and practice as a class warm-up activity.

Alternate Activities:

1. Require older students to include more details, such as common plant illnesses and remedies.
2. For large groups: divide students into groups, each with a particular focus – taking care of specific types of plants or specific types of animals.

Evaluation:

Song creation and performance.
Discussion and participation in the activity.



CLASSROOM LESSON

How Do Different Surfaces Affect Air Temperature?

Discipline:

Science

Objectives:

Understand how different materials affect air temperature.
Improve observation skills

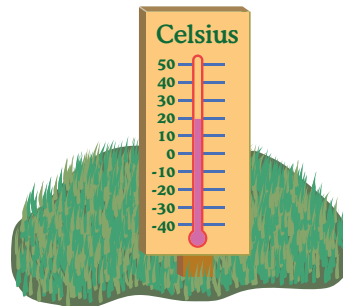

Standard Course

Objectives:

Month or Unit:

Materials:

Measuring instrument with a 10 cm. mark.
Thermometer
Clock or watch
Class journal

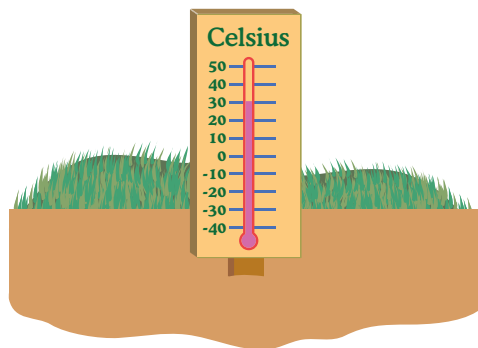

Proposed Activities:

1. Select at least 4 sunny locations around your school building with different kinds of surfaces. Choose places that have some shade, some grass, are in the garden, and are on the cement or dirt soccer field.
2. Use a chart like the one which follows. Ask students to predict the air temperature in each location.
3. Instruct students on the proper way to hold the thermometer:
 - so that it is straight up
 - so that it is 10 cm. above the surface
 - so that the heat from your hands does not affect the temperature
 - with the bulb facing away from direct sun rays
4. Go to each location as a group; have a different student measure the air temperatures. After 2 minutes, read and record the temperature.
5. When you have finished collecting the temperature data, discuss the results.

How Do Different Surfaces Affect Air Temperature? Observations Chart			
Location	Surface	Predicted Air Temperature	Actual Air Temperature
1.			
2.			
3.			
4.			

Evaluation:

What did you learn?

1. What were the lowest and highest temperatures?
Answers: Will vary. Discuss the differences between the highest and lowest temperatures.
2. Which surface had the lowest reading?
Answer: grassy surfaces.
Which surfaces had the highest readings?
Answers: cement, bare dirt.
3. How did your predictions compare with the readings?
Answers: Will vary. Help students improve their abilities to predict.

Using what you learned:

1. Which surface would warm your water fastest?
Answer: the cement or hard surfaces.
2. Which surface is the best for growing fruits and vegetables in the garden?
Answer: Probably the garden or grass. While the grass is a little cooler, it still is able to use the heat from the sun to give energy to the plants.



CLASSROOM LESSON

How Does Running Water Change a Landscape?

Discipline:
Science

Objectives:
Understand erosion
Improve observation skills
Note: This activity works well when followed by the next activity *How Do Roots Prevent Soil Erosion?*

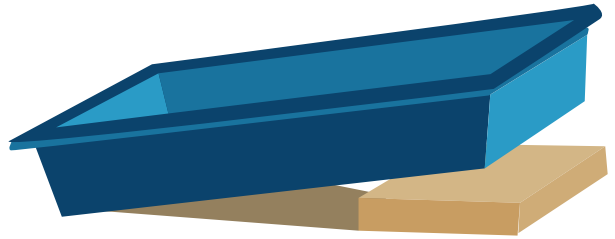

Standard Course Objectives:

Month or Unit:

Materials:
Soil
Large, shallow pan
Cup
Water – 5 L
Marking pen
3 wooden blocks or cement slabs or 10-15 books
Class journal

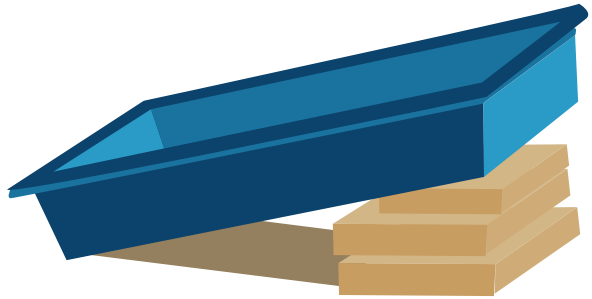

Proposed Activities:

1. Make a "micro-landscape" with a hill of slightly moist soil at one end of the pan. Leave half of the pan empty to collect water.
2. Draw a picture of the landscape.
3. Place 1 block or a few books under the hill end of the pan.
4. Have a student pour water from the cup slowly, like a slow and steady rainfall on the hill.
5. Record the changes you observe in a chart like the one which follows.
6. Draw a picture of the new landscape.
7. Place 2 more blocks or some more books under the hill end of the pan.
8. Have a student repeat steps 4-6.
9. Record your observation in a chart like the one which follows.
10. When you are finished, discuss the observations and results.

How Does Running Water Change a Landscape? <i>Observations Chart</i>	
Water	Changes
Pan with -1 block -a few books	
Pan with -2 or more blocks -several books	

Evaluation:

What did you learn?

- Where did the erosion happen in your landscape?
Answer: Accept students' observations and help them conclude that most erosion occurred in the high regions of the landscape.
- Where were materials deposited?
Answer: Where the running water slowed, especially in the low areas.
- What does erosion do to the landscape?
Answer: Wears it down.
- How did the increase in slope affect the erosion of soil?
Answer: More material was eroded and larger material was moved farther.

Using what you learned:

- Describe how you think a landscape would look after many years of erosion by water.
Answer: The landscape would be more level. Higher areas would be carried away; lower areas would fill in. May see crevasses in the hillside.
- How would erosion and deposition affect a steep landscape?
Answer: The erosion of the landscape would be increased if the slope were increased. Deposition would increase.
- How would erosion and deposition affect a nearly flat landscape? Plan, experiment, and test your predictions.
Answer: Erosion and deposition would be decreased if the landscape were nearly flat.
- Some land is hilly. How can we help decrease erosion in the hilly areas?
Answer: Maintain vegetation year-round. Plant across the hills instead of up and down to stop the soil from eroding.



CLASSROOM LESSON

How Do Roots Prevent Soil Erosion?

Discipline:
Science

Objectives:
Understand the role of vegetation
in preventing soil erosion.
Improve observation skills.

Standard Course Objectives:

Month or Unit:

Materials:
2 large shallow pans
Cup
Piece of sod
Soil
Books or blocks
Water
Scissors or blade to cut grass
Class journal

Proposed Activities:

1. Have a student cut off the blades of grass from the piece of sod so only the roots remain. Place the piece of sod in one end of the pan.
2. In the second pan, have a student pack enough loose soil so it is about the size and height of the soil in the piece of sod.
3. Have the students tilt their pan by resting one end of each on about 5 or 6 books, stones, or boards. (Each stack should be the same height.)
4. With the cup, have each student water the contents of his/her pan. Use the same amount of water for each pan. Pour the water slowly, like a slow and steady rain.
5. Observe the runoff materials in each pan and record your observations on a chart like the one which follows.

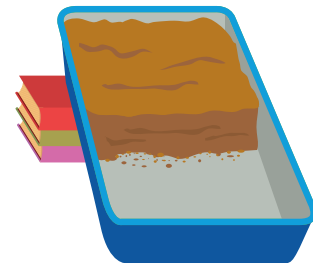

How Do Roots Prevent Soil Erosion? Observations Chart	
Pan 1 With sod	Amount of Runoff
	Material in Runoff
Pan 2 With loose soil	Amount of Runoff
	Material in Runoff

Evaluation:

What did you learn?

- How were the piece of clipped sod and pan of loose soil different? Why did you need to cut off the blades of grass?
Answer: We needed to see how the blades of grass affected the soil. The roots were left.
- Which pan contained the least amount of runoff materials? Why?
Answer: The pan with the grass sod contained the least amount of runoff materials because the soil was held together by roots.
- What did you find in the runoff from each pan?
Answer: There was more loose soil in the runoff from the pan without the sod.

Using what you learned:

- What do the roots of trees and forest plants do for the soil?
Answer: They hold the soil together and prevent erosion of the topsoil.
- In addition to soil erosion, what other problems are caused by completely clearing a forest area?
Answer: The habitats of many animals and plants are destroyed and rainwater runs off instead of being absorbed by the soil.
- Why is reforestation important?
Answer: To preserve the forests for use by future generations of organisms, including people.
- What are some things we can do in our villages to prevent erosion?
Answers: Will vary.



CLASSROOM LESSON

Measuring Rainfall

Disciplines:

Geography (Map Reading)
Mathematics
Science
Social Studies

Objectives:

Understand how rainfall affects the climate and garden
Improve observation skills

Standard Course Objectives:

Month or Unit:

Materials:

Rain gauges
Class journal
Textbook or reference book map of rainfall in Africa (optional)

Proposed Activities:

1. When rain is expected, have students place 2 or 3 rain gauges around the school grounds (in the garden, near the road, and in the play/soccer area).
2. Measure the rain every day for a particular amount of time and record the amount in a notebook, using a chart like the one which follows. Record the day, location of the gauge and amount of rain. Try to measure at the same time each day. After measuring, empty the gauge. What time of the day does most of the rain come?
3. Measure or observe the growth of the garden. Is plant growth correlated to precipitation? How? (Add columns to your chart for noting the measurements of additional plants at each location.)
4. Calculate the average amount of rain by location and/or by day or week.

Measuring Rainfall (and Growth) Observations Chart (Try to measure the rainfall at the same time each day.)							
		Location 1		Location 2		Location 3	
Date	Time	Amount of Rain	Height of Plant	Amount of Rain	Height of Plant	Amount of Rain	Height of Plant

Evaluation:

For science disciplines:

1. How many centimeters of rain does your school receive, on the average? What is the most rainfall received in one day?

Answers: Will vary.

2. At what times of the year does most rain fall?

3. At what time of day does most rain fall? Morning, afternoon, evening?

4. What locations have the most rain? The least?

For mathematics disciplines:

Correct calculations of averages.

Using what you learned:

1. How does the amount of rain influence the growth of the garden?

Answer: Too much rain can damage the plants. Too little rain, the plants will not grow.

2. If the rain comes at particular times of the year, how does that influence when we plant our garden?

Answer: It is important to time planting so plants will grow during the rainy season. Seedlings must have time to establish strong roots before rains come, otherwise plants could be damaged and/or washed away during heavy rains.



3. Is a lot of rain always good?

Answer: Not always. Some plants need only a little moisture. Also, we do not want the plants to wash away. When it is too wet, plants will not establish good roots and then cannot absorb the nutrients in the soil.

4. What are the implications of the amount of rainfall in your area for your garden?

Answer: For food security.

5. Why does the government measure and record rainfall?

Answer: They can anticipate which areas of the country will have inadequate rainfall. This is useful for establishing food and irrigation policies, developing housing for people, developing crop varieties, and other policies and programs.



CLASSROOM LESSON

Geometry in the Garden

Discipline:

Mathematics – Level 5

Objective:

Calculate the area of a garden bed by using a measurement tape.

Materials:

Syllabus copy

Measurement tape (2 decameters)

This activity takes place in the garden, next to 2 garden beds.

Proposed Activities/Performance Objectives:**1. Beginning**

Ask students to count in tens (100-200).

Ask students to say the multiplication table by 5s.

2. Presentation

Check prior knowledge by asking students to state measurement units of geometric length.

Answers: meter, cm., dm., km.

Check prior knowledge by asking students for the formula for calculating area.

Answer: (length X width)

3. Practice

Show students the measuring tape.

Explain the features – units of measure, measurement starts with 0, total length. Demonstrate how to use the tape.

4. Practice

Ask two groups of students to measure the length and width of the two beds in the garden.

Answer: The teacher should know the correct length and width ahead of time to verify that the students have measured correctly.



5. Production

Ask students to calculate on their slates the area of the two beds. Ask students to write down the lesson summary. Write down the summary in the teacher's copybook.

6. Evaluation

Ask students for the answer to the calculation of the area of each of the 2 beds. Ask how this practice could be applied when measuring other areas. Ask for examples.

7. Conclusion

Provide feedback to the learners. Inform them of the next step in the lesson.

This lesson was developed by: Thomas MABIKANA, Jean NGAMVALA, Obongo OLEKONO, and Jean Pierre TSAMBA, Lekoumou District, Republic of Congo. It was the second-place winner in a lesson development competition as part of the School Garden Teacher Training conducted by the U.S. Department of Agriculture, January 2007.

Geometry in the Garden

Objective:

Calculate the area of a garden bed using a 2 decameter measurement tape.

Proposed Activities/Performance Objectives:

1. Beginning - Count from 100-200 in tens. Recite multiplication table by 5s.
2. Presentation - State measurements of geometric length.
3. Practice - Demonstrate the features of and how to use a measuring tape.
4. Measure the length and width of garden beds.
5. Production - Write a lesson summary.

1 2 3 4 5 6 7 8 9 10 11 12 13 14 15 16 17 18

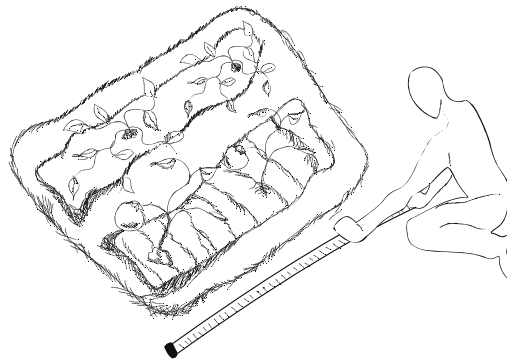

CLASSROOM LESSON

Which Soil Soaks up More Water?

Discipline:

Science

Objectives:

Understand how soil condition affects water infiltration
Improve observation skills

Standard Course Objectives:**Month or Unit:****Materials:**

2 different kinds of soil
(perhaps some from the garden and some from the roadside)
2 medium to large clear plastic bottles or metal cans
Water
Cup
Watch with a second hand
Marking pen
Class journal

Proposed Activities:

1. Fill each bottle half full with a soil. Pack it down.
2. Label each bottle/can with the type of soil.
3. Pour 1/2 cup of water in each bottle or can with soil. With the watch, see how long it takes for the water to soak into the soil. Record the number of seconds on a chart like the one which follows.
4. Add 1/2 cups of water until the soil cannot soak up any more. Record the number of cups on a chart like the one which follows.

Evaluation:

Answers:

Soaking time answers will vary but should indicate that the garden soil soaks up water faster.

Number of cups answers will vary but should show that the garden soil soaks up more water.





Which Soil Soaks up More Water? Observations Chart		
Soil Type	Soaking Time	Number of Cups
Garden (with compost)		
Roadside (without compost)		

What did you learn?

1. Which soil soaks up water faster?
Answer: Sandy soil soaks up water faster.
2. Which soil soaks up the most water?
Answer: Garden soil holds more water because it has more organic matter. It requires more cups of water to fill the soil.

Using what you learned:

1. Which soil would have the least runoff during a heavy rain? Why?
Answer: The garden soil would have the least runoff. It soaks up water faster than the hard, poor, soil from the roadside.
2. Which kind of soil would have the largest mud puddles after a heavy rain? Why?
Answer: The soil from the roadside and soil like it that is hard and low in organic materials, because the water would not soak in as fast.
3. Which type of soil is better for the garden? Why?
Answer: The soil enriched with organic matter is better for the garden. That matter not only helps the plants, it helps manage soil moisture.



CLASSROOM LESSON

What Does the Plant Factory Need?

Discipline:

Science

Objectives:

Understand how water and sun affect plant growth.
Improve observation skills.

Standard Course Objectives:

Month or Unit:

Materials:

3 identical bean plants in cans the same size
String and piece of paper to label each plant
Marking pen
Water
Ruler
Class journal

Proposed Activities:

1. Label the Plants A, B, and C.
2. Add water to Plant A until the soil is moist. Put Plant A in a dark place.
3. Add the same amount of water to Plant B. Put Plant B in bright sunlight.
4. Do not water Plant C. Put Plant C in bright sunlight.
5. Add water to Plants A and B every other day.
6. Measure each plant for 10 days. Record your observations on a chart like the one which follows.

Evaluation:

Observation Answers:

After 10 days...

Data should show Plant A grows but not well, Plant B grows the best, Plant C grows the least.

What did you learn?

1. Which plant is tall and healthy?

Answer: The plant that had sun and water (plant B) should look tall and healthy.

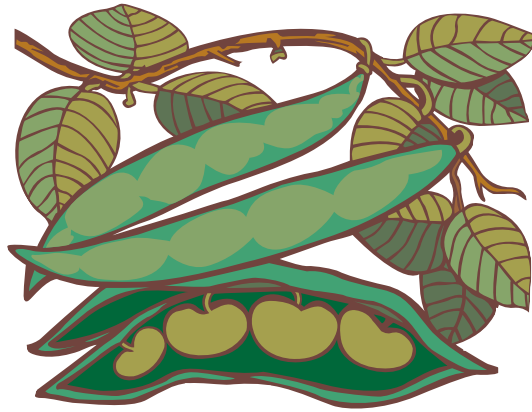



What Does the Plant Factory Need? Observations Chart			
	Plant A Watered, no light	Plant B Watered, bright light	Plant C No water, bright light
Day 1			
Day 2			
Day 3			
Day 4			
Day 5			
Day 6			
Day 7			
Day 8			
Day 9			
Day 10			

2. Which plant is tall but doesn't look healthy?
Answer: The plant with water in the reduced light (plant a) should be tall but have limited foliage. It may also be pale green or yellow.

3. Which plant grew the least?
Answer: The plant without water (plant C) probably died.

Using what you learned:

1. What do plants need to grow?
Answer: The needs of the plants are varied; however, all plants need water and light in order to make food and grow.

2. What would happen if you kept the soil soaked with water all of the time?
Answer: Too much water is a problem for plants also. Roots that stand in water have difficulty getting the nutrients they need from the soil.

3. How can we make sure the plants in our garden get the right amount of water to grow?
Answer: Irrigate, water, use mulch to conserve moisture. Best to get plants started before the rains are too heavy so they can establish roots and obtain the nutrients they need from deeper in the soil.

CLASSROOM LESSON

Soil and Organic Matter Experiment

Discipline:

Science

Objectives:

Understand how compost affects soil

Standard Course Objectives:**Month or Unit:****Materials:**

2 cups of soil that is hard and sticky
½ cup of compost
2 plates
Water
Mixing bowl or bucket

Proposed Activities:

1. Write COMPOST on one plate and NO COMPOST on the other. (If you cannot write on the plates, use two differently colored plates and write on the chalkboard which color is COMPOST and which is NO COMPOST; save the information so you and the students can refer to it later.)
2. Measure 1 cup of soil. Place the soil in the bowl. Add enough water to the soil to make a mud cake. (A soil low in clay will not hold together well, so you may have to try some different soil.) Put the mud cake on the plate marked NO COMPOST.
3. In the bowl, mix the other 1 cup of soil with the ½ cup of compost. Add water to the mixture to make another mud cake. Put this cake on the plate marked COMPOST.
4. Put both plates in the sun to dry. When the cakes are completely dry, break them with your fingers.
5. Observe the differences in the two cakes. Have the students feel the cakes on each plate.

Evaluation:

Discussion and participation in the activity.



CLASSROOM LESSON

Describe an Ecosystem

Disciplines:

French

Science

This activity works well after discussing ecosystems.

Objectives:

Develop creativity in describing science

Use questioning techniques

Improve observation skills

Standard Course Objectives:

Month or Unit:

Materials:

Paper and pencil/pen

Proposed Activities:

1. Take the class to the garden or somewhere else outside the classroom. Have the students look around at the ecosystem. Discuss some of the things they might be seeing.
2. Ask the students to describe an ecosystem, in writing. Remind them that some parts of the ecosystem may be visible to them, while other parts will not.
3. Provide guidelines for the students on the description, length, etc. Keep in mind that you will need to evaluate the quality of the description.
4. Ask some of the students to share parts of their description with the rest of the class. Ask the other students to comment on the accuracy of the content and the use of the terms used.

Alternate Activities:

Have students interview each other in pairs. One student can pretend to be a writer for a local newspaper. The second student can pose as a part of the ecosystem (people are!) and should describe the ecosystem. The second student can also take the role of another living organism – a leaf, soil, water, carrot, etc.

Evaluation:

Correct use of vocabulary. Composition, sentence structure.

Questions asked by the interviewer.

Discussion and participation in the activity.

CLASSROOM LESSON

How Do Plants Reproduce from One Parent?

Discipline:
Science

Objectives:
Understand vegetative reproduction
and how it can be used in the
garden.
Improve observation skills.

Standard Course Objectives:

Month or Unit:

Materials:
Sweet potato/yam
Large plastic bottles or tins with top
cut off
Four small sticks/twigs
Plant cutting
Water
Class journal

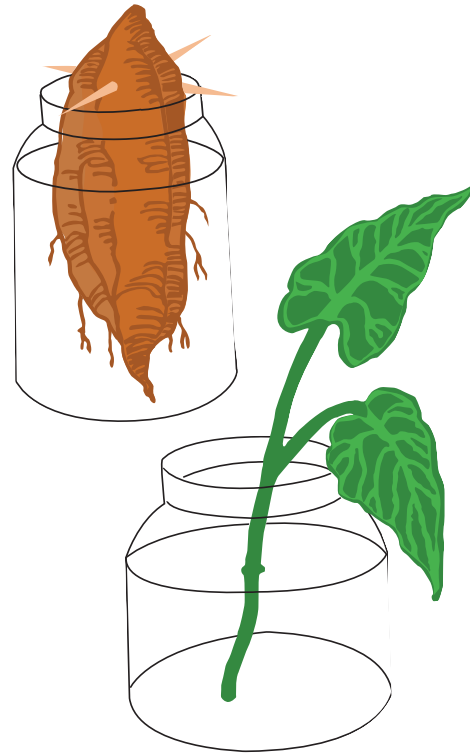

Proposed Activities:

1. Place a sweet potato in a large bottle of water so that at least half of the potato is under water. If needed, use wood sticks to hold the potato. (Only part of the potato should be immersed.)
2. Keep the bottle in a dark place for a few days. After some roots have formed, place the jar in a warm, well-lit place.
3. Place the plant stem cutting in a small bottle of water. Put the bottle in a warm, well-lit area.
4. Observe the sweet potato and plant cutting several times a week for 3 weeks. Add water to the sweet potato when needed. Replace the water around the plant cutting every other day.
5. Record your observations each week on a chart like the one which follows.



How do Plants Reproduce from One Parent? <i>Observations Chart</i>			
Item	Week 1	Week 2	Week 3
Sweet potato			
Plant cutting			

Evaluation:

What did you learn?

1. What changes did you observe in the sweet potato and plant cutting?

Answer: New parts began to grow.

2. What was the new growth in the sweet potato?

Answer: The sweet potato grew stems and leaves.

3. What was the new growth in the plant cutting?

Answer: The plant cutting grew roots.

Using what you learned:

1. If you planted the sweet potato and plant cutting in the garden, what do you think would happen?

Answer: They would grow into new plants.

2. How many parent potato plants are needed to reproduce?

Answer: One parent potato plant is needed. This type of reproduction is called vegetative reproduction.

3. How can this help us in our garden?

Answer: We need to save some potatoes or cuttings to grow new plants. Then we do not need to buy seeds.

CLASSROOM LESSON

Where Do Plants Store Food?

Disciplines:

Science

This activity builds on the previous activity: *How do Plants Reproduce from one Parent?*

Objectives:

Understand how plants use stored food
Improve observation skills

Standard Course Objectives:

Month or Unit:

Materials:

2 potatoes: 1 whole, 1 cut in half
2 onions: 1 whole, 1 cut in half
2 plates or bowls (or old newspaper)
Class journal

Proposed Activities:

1. Have students look at the cut onion and potato. Ask them to draw a picture of what they see.
2. Place a whole onion and a whole potato on plates or bowls and set them aside in the classroom.
3. Have students observe the potato and the onion for three weeks. Ask them to draw or describe what they observe on a chart like the one which follows.

Where Do Plants Store Food? <i>Observations Chart</i>			
Item	Week 1	Week 2	Week 3
Potato			
Onion			



Evaluation:

What did you learn?

1. How did the potato change?

Answer: The potato began to sprout. Shoots grew up and roots grew down. The potato shriveled because it used the food in the potato to grow sprouts.

2. How did the onion change?

Answer: The onion sprouted leaves above and roots below. The outer layer of the onion shriveled.

3. Why do you think they began to change?

Answer: The onion and potato were exposed to light and used the stored food to grow. They shriveled because they used the food to grow sprouts and leaves.

Using what you learned:

1. What are some of the plants that we have in our garden that store food this way?

Answers: Will vary. Perhaps cassava, yams, onions.

2. How does this relate to people?

Answer: The food stored in plants is the source of food for us.

3. How did the onion change?

Answer: The onion sprouted leaves above and roots below. The outer layer of the onion shriveled.

4. Why do you think they began to change?

Answer: The onion and potato were exposed to light and used the stored food to grow. They shriveled because they used the food to grow sprouts and leaves.



CLASSROOM LESSON

Which Items are Biodegradable?

Discipline:
Science

Objective:
Understand what kind of items decompose

Standard Course Objectives:

Month or Unit:

Materials:

Refuse such as aluminum can, glass jar, plastic bag, plastic bottle, paper, banana peel
4 stakes/sticks
String
Meter measurement
Hoe
Class journal

Proposed Activities:

1. Use stakes and string to mark off a one square meter area in the school yard. Remove the soil to a depth of 30 cm. in the area.
2. Place the refuse in the bottom of the pit you have made. Separate the items so they do not touch.
3. Have students make a top-view map of the pit. Instruct them to mark the location of each item. Ask students to predict what will happen to the items in the pit. Write down their answers.
4. Carefully replace the soil in the pit. Do not disturb the refuse as you cover it with soil. Wait 30 days.
5. Carefully reopen the pit. Observe. Ask the students to write a description of each item.
6. Remove the items and dispose of them in a refuse container. Try to make the area look like it did before you dug the pit, or better.



Evaluation:

What did you learn?

1. What changes happened in the pit?

Answer: Students should mention both chemical and physical changes. Some of the items will have started to decompose, such as the paper and the banana peel. Other items, especially those made of metal or plastic, will remain relatively unchanged.

2. Were these results what you expected? Explain.

Answers: Will vary. Refer back to the predictions the class made when you dug the pit.

Using what you learned:

1. Suppose you put all the items back in the pit and closed it. What would you expect to see if you reopened it after 30 more days?

Answer: The biodegradable items would be more decomposed. The other items would not change significantly.

2. What could you do to eliminate the amount of items along the roads or in the homesteads that do not biodegrade?

Answer: It is best not to buy them. Re-use items, if possible. Dispose of items properly.

CLASSROOM LESSON

Seed Germination Experiment

Disciplines:

Mathematics/Statistics
Science

Objective:

Understand how to test seed germination rates (seed viability).

Standard Course Objectives:

Month or Unit:

Materials:

Seeds (minimum of 20)
Clean cloth – 2 pieces
Clean water
Class journal

Proposed Activities:

1. Select the type of seed you want to test – beans, carrots, spinach, etc. If you obtain seeds from different sources, be sure to label them and keep them separate for a separate germination test.
2. Soak the pieces of clean cloth in clean water. Wring out the cloths so they do not drip. Place a minimum of 20 seeds in organized rows on one of the cloths. Cover it with the second piece of cloth and loosely roll up the cloths. Repeat the test for other types of seeds or the same types of seeds from different sources. Label each roll of cloth with the type of vegetable, source of the seeds and the date.
3. Place the rolled cloth in shade for 5-7 days. Unroll the cloth and examine the germination. Most seeds that are viable will have germinated by then.
Count the number of seeds tested. (e.g., NS=20)
Count the number of seeds that germinated (e.g., GS=14).
4. Calculate the germination rate.
(See example in box at right.)
5. Record the germination rate (GR).

$$\frac{GS}{NS} = \frac{14}{20} = GR 0.7, \text{ or } 70\%$$

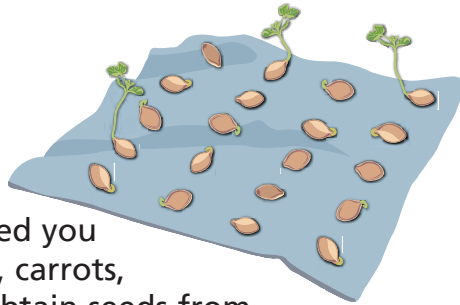

Evaluation:

What did you learn?

1. What was the seed germination rate? Is this good or bad?

Answer: Varies depending upon seeds tested.

The number should be between 0 and 100%.

85 - 100% good

51 - 84% fair

0 - 50% poor

2. What factors influence the viability of seeds?

Answer: Numerous factors influence seed viability including the variety of the seed, the age of the seeds and the conditions in which they were stored.

Using what you learned:

1. This experiment used a special type of mathematics to determine a rate. What is this called? Can you think of any other applications?

Answer: This type of mathematics is called statistics. Statistics are used for many different types of situations in which a small sample of a population is tested to infer information about the entire population.

2. What other simple statistics problems can be developed from the garden?

Answer: There are many possibilities. Examples: the survival rate of different types of plants. The amount of fruit per plant that different plants produced.

3. If a seed has a low germination rate, what should we do?

Answer: Plant more of them to increase the number of those that germinate. Then there will be more plants. If the school has access to seeds from different sources, plant the seeds that have the highest germination rate.

4. How can we improve the germination rate of our seeds?

Answer: Collect and save seeds appropriately. Collect and save seeds from those species that have a high germination rate and that produce well and are free of disease.



CLASSROOM LESSON

Insects in the Garden

Discipline:

Science

Objectives:

Describe the effect of insects on the garden
Determine if insecticides are needed in the garden

Materials:

Sample of insects – Stinking cricket and other insects – beetles, caterpillars.
Samples of vegetable plants affected by insects.
Samples of healthy vegetable plants, not affected by insects.

Proposed Activities/Performance Objectives:

1. Beginning – Build interest in the lesson by asking students to state the names of some of the insects they know.
2. Presentation – Present a cricket to the students. Ask them what they see. Repeat this process with other insects.
3. Practice – Show students some plants affected by insects. Ask students the names of the plants or tell them.

Compare the affected leaf/plant with a healthy one.

Ask students what they see.

Answer: The sick plants have holes, chewed spots, or other damage.

Ask students what causes the damage.

Answer: Insects.

4. Practice – Ask questions about crickets and other insects – the effect on the garden, on crops, etc.

Where can you find crickets?

Are crickets good or bad for the garden?

What happens to a plant or its fruit if an insect attacks it?

Are insects good or bad?

Answer: Some insects are good because they eat harmful insects. Some insects are bad because they damage plants.



5. Production – State strategies for managing crickets and other insects. Ask students for ways of keeping insects out of the garden.

Answers:

- *Clear plants and weeds 2-5 meters on the outside of the fence around all sides of the garden so insects cannot jump into the garden.*
- *Plant a root crop such as cassava around the outside of the garden fence. This will reduce the insects coming into the garden.*
- *Plant other fragrant plants, such as marigolds near the vegetables.*

Ask students how to keep insects from damaging vegetables if they do get into the garden.

Answer: Removal by hand and/or insecticides.

6. Evaluation – Have students state how insects can damage plants. Have them state different ways to prevent insect damage.
7. Ending – State the next class topic will be how to make natural insecticides.

This lesson was developed by: Daniel MBAMA, Jean Raymond MBAMA, Jean MAVOUNGOU, Daniel MOUANDA, Alphonse MOUKALA, and Jean Kleber MOUKO. Lekoumou District, Republic of Congo. It was the first-place winner in a lesson development competition as part of the School Garden Teacher Training conducted by the U.S. Department of Agriculture, January 2007.

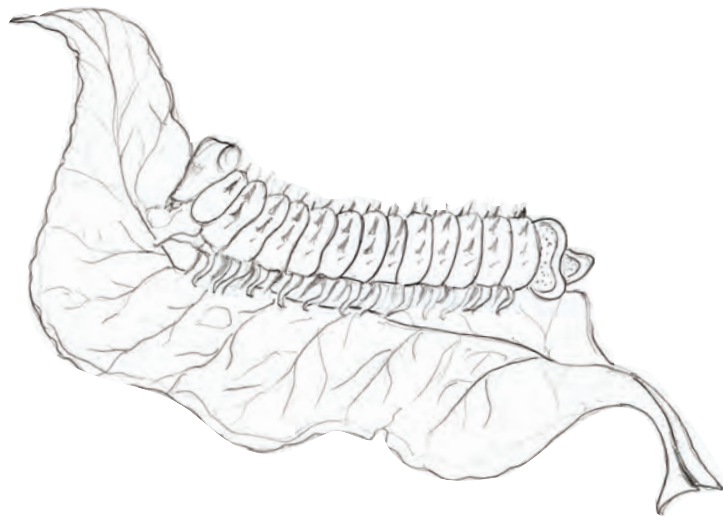

Caterpillar drawing by David MOUKOUYI.

MORE CLASSROOM LESSONS

French

- Write about the rain, the garden, harvesting, working together, what they have learned in the garden, or other concepts important to the school garden.
- List words that rhyme with the names of some of the plants. Use the words to write a poem about the garden.

Other:

Geography (Map Reading, Map Making)

- **Maps**
Draw a map of the classroom. Discuss relationship and scale. Draw a map of the garden. Discuss the benefits of drawing fewer details, rather than too much detail. How can maps help us?
- **Rainfall**
Show maps of the rainfall or topography of your country. Discuss the implications for your garden – the growing cycle, erosion, irrigation, soil quality, etc.

Other:



MORE CLASSROOM LESSONS

Continued

Mathematics

Have teachers develop math story problems appropriate for their curriculum, using the garden as the context or application.

- Use the meter measures to have the students measure the garden, the school, the classroom, or other parts of their environment. Have them work in teams and compare their results to see if they are correct.
- Have the students measure their foot or hand and calculate how many "feet" or "hands" it is from one end of the garden to the other. Measure fingers to use as a guide to determine how far down in the dirt to plant the seeds.
- Measure or calculate the distance between plants, rows, etc.
- How much does the produce from the garden weigh? Use a variety of formulas to determine, for example, how much 10 carrots weigh. Compare the weight of different foods.
- Discuss volume vs. mass. Which is heavier, one pail of yams or one pail of beans. Why?
- Find out how much rice the cooks prepare for one day and how many students are in the school. Calculate how much each student would get.

Other:



MORE CLASSROOM LESSONS

Continued

Music

- **Ant Chant**

Point out that all insects have three body parts and six legs. Then divide students into groups of three to form ants: the first person is the head, the second person is the middle (thorax), and the third person is the stomach (abdomen). Have the second and third student place their hands on the shoulders of the student in front of them.

Ask the students to practice walking together in rhythm, slowly chanting "left, right, left, right..." until their steps are together.

Next, have them try marching to the "Ant Chant." Ask them to take turns as leader.

"Ant Chant" (slowly)
Left and right, left and right,
Ants work hard all day and night.
Left and right, left and right,
Don't get left, step just right. (repeat)

- **Optional**

Students can make up their own chants.

Other:



MORE CLASSROOM LESSONS

Continued

Science

- **Compost**

Compare the pit compost methods described with an area where everything is thrown together randomly. See the difference in how fast they decompose. Measure the temperature in the compost pile. Compare it to other temperatures in the garden or school. Why is the compost hotter than the garden?

- **Decomposition**

Observe a dead log, what it attracts, what grows on it, and what happens.

- **Transpiration**

Put a plant in a plastic bag or closed clear plastic bottle. What happens to it? Put a plant in some water with some dye (berry juice). What happens to the plant? Why?

- **Seed Spacing**

Plant carrot seeds in different thicknesses. Thin some. Leave others. What happens to the carrots as they grow? Which practice provides the best carrots?

- **Insect Watch**

Have students walk around the school yard, village or their homestead to identify the most common local insects. Compare and discuss observations. What conclusions can be drawn?

- **Cocoon Collecting**

Take a nature walk as a class. Collect a cocoon and bring it back to the classroom. Place it in an appropriate place for observation. Have the students note any changes in their garden journal. What is a cocoon? What happens to a caterpillar when it leaves the cocoon?

- **Honey**

Many people do not understand the role of bees in gardening and the overall ecology. Invite a beekeeper to bring an inactive hive to show and handle and to discuss the roles of bees in a hive. Besides showing what to wear when working with the bees, have the beekeeper demonstrate how to retrieve the honey.

Other:

MORE CLASSROOM LESSONS

Continued

Social Studies

- Discussions or activities that relate to cooperation and team work, health and nutrition.

Other:

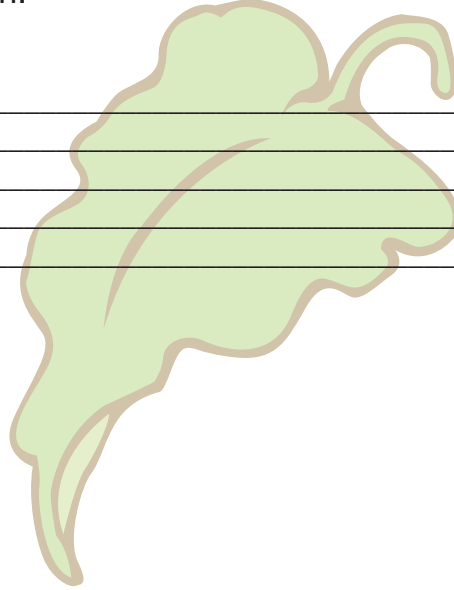

c. Lesson Plan Framework



Lesson Plan Framework						
Class: Date and Period: Lesson:	Objective: Materials:	Learner Strategies	Teacher Strategies	Content	Evaluation	Timing
Beginning: Building up learners' interest in the lesson.						
Presentation: Exposing learners to new notion.						
Practice: Leading learners into the manipulation of new notion.						
Production: Leading learners into new notion-related tasks (controlled; semi-controlled; guided; free).						
Ending: Providing and obtaining learners' feedback. Informing learners about next step.						

SECTION III

Appendices

This Teachers Guide was developed as one of several resources for training primary school teachers in the Republic of Congo. Therefore, it is important to remember that some of the plants, pests and growing advice contained in this manual may need to be adapted to better fit your home country, city or village. That said, many of the techniques outlined in this manual are applicable worldwide. The Manual can stand alone as a source of information, and includes steps for developing a school garden and for engaging the community in school garden management. It also details ways teachers can bring the garden into the classroom, and includes additional materials that were developed to enhance teacher training and student education.

The first three pages of the Manual provide a context and purpose for the Manual. We include here additional resources and materials so that organizations and schools throughout Africa or other continents can use and/or revise the Manual to help them provide training appropriate to their goals and contexts.

Appendices

A. Classroom Posters

- Benefits of a School Garden
- Parts of a Plant
- Lifecycle of the Garden
- Photosynthesis

B. Quick Gardening References

- Compost as an Organic Fertilizer
- Tips for Successful Seeding of Vegetables
- Practice Crop Rotation in the Garden
- Organic Solutions to Control Pests and Disease
- Steps to Minimize Diseases of the Tomato Plant

C. Teacher Training Agendas and Evaluation Instruments

- Phase I
 - Teacher Training Agenda
 - Teacher Training Evaluation Instrument
- Phase II
 - Teacher Training Agenda
 - Teacher Training Evaluation Instrument

D. Project Monitoring and Evaluation Instruments

- Phase I: School Garden Monitoring Record (NGO)
- Phase II: School Garden Monitoring Record (NGO)
- Phase II: School Garden Visits Evaluation Instruments (USDA)
- Phase III: School Garden Visits Evaluation Instruments (USDA)

APPENDIX A: Classroom Posters

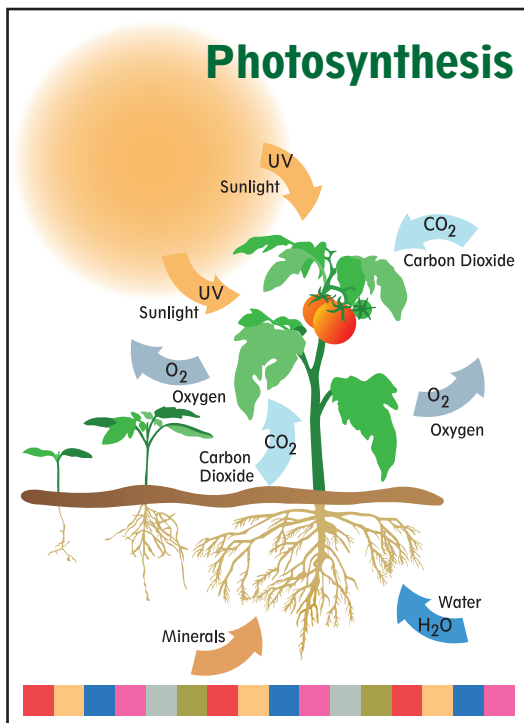
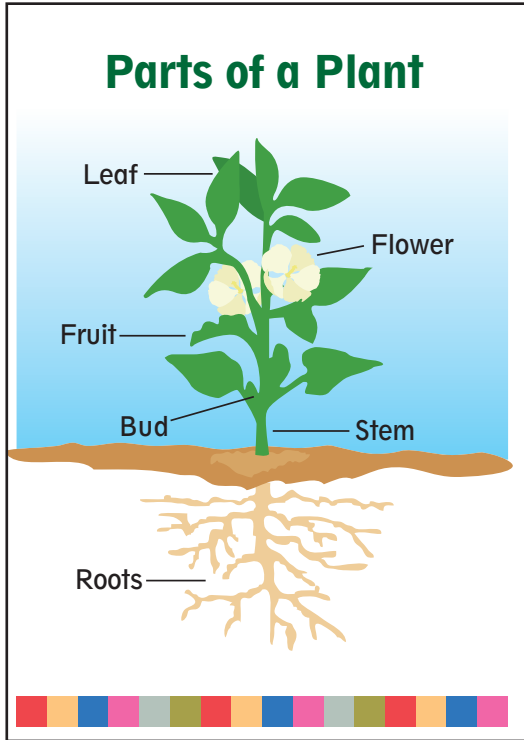
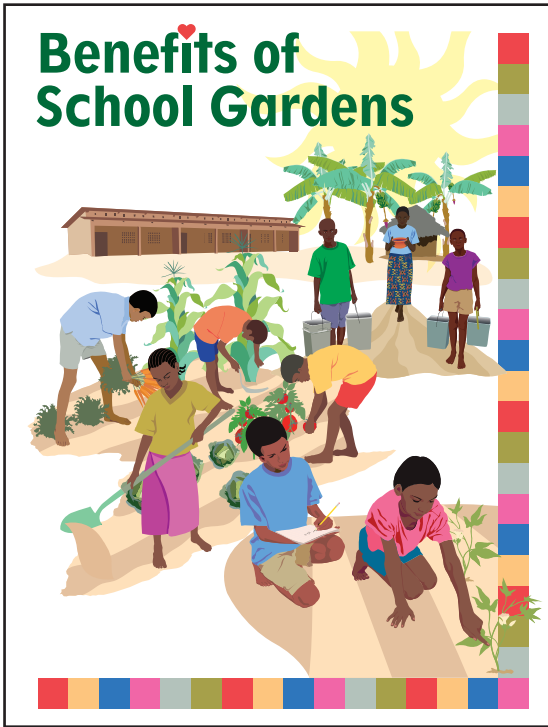

APPENDIX B: Quick Gardening References



Teacher's Guide to **Primary** School Gardens: School Level

Compost as an Organic Fertilizer



- ✿ Make compost above ground in a heap or below ground in a pit.
- ✿ Start with a layer of brown materials (high in carbon), alternate with layers of rich, green materials (high in nitrogen).
- ✿ Chop all materials into smaller pieces.
- ✿ Add water in the dry season.
- ✿ Sprinkle in garden soil or mature compost as you make the pile.
- ✿ Cover the pile with banana or palm leaves to maintain moisture.
- ✿ Turn the pile once every two weeks until the compost is complete.
- ✿ Compost is ready when it does not heat or smell and when original materials are not recognizable.
- ✿ Add a handful of compost when transplanting vegetables.
- ✿ Compost supplies nitrogen, phosphorus and potassium in a 2-1-1 ratio.



For more information refer to the Manual (Teacher's Guide to School Gardens: Primary School Level).

Teacher's Guide to **Primary** School Gardens: School Level

Tips for Successful Seeding of Vegetables



1. Plant about one third of the package of seeds at one time.
2. In a month or so plant another third of the seeds.
3. In another month, plant the last of the seeds.
4. When seeding in the nursery, create a small trench to hold moisture.
5. Mix a little compost with the soil in the trench.
6. Sprinkle the seeds along the trench.
7. Cover with fine soil to a depth equal to two times the width of the seed.
8. Water carefully and slowly to avoid washing seeds away.
9. Continue to water the seeds and young plants daily or when dry.
10. Thin out weak nursery plants to allow strong ones to grow.
11. When the plants are older, water less often but deeply each time.

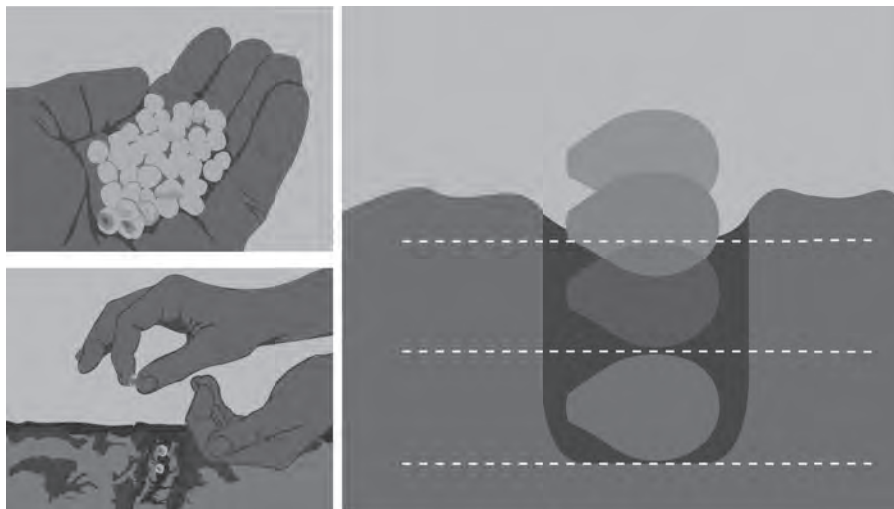

For more information refer to the Manual (Teacher's Guide to School Gardens: Primary School Level).

Teacher's Guide to **Primary** School Gardens: School Level

Practice Crop Rotation in the Garden



Crop rotation means planting a vegetable that is in a different crop family from the one just harvested. Crop rotation is important in disease and insect control.

Three crop families are very important to rotate:

1. **Leafy Vegetable family** includes cabbage, amaranth, endive and spinach.
2. **Fruit Vegetable and others family** includes tomato, white potato, eggplant, pepper, and lettuce.
3. **Vine family** includes cucumber, pumpkin, squash, zucchini, and watermelon.

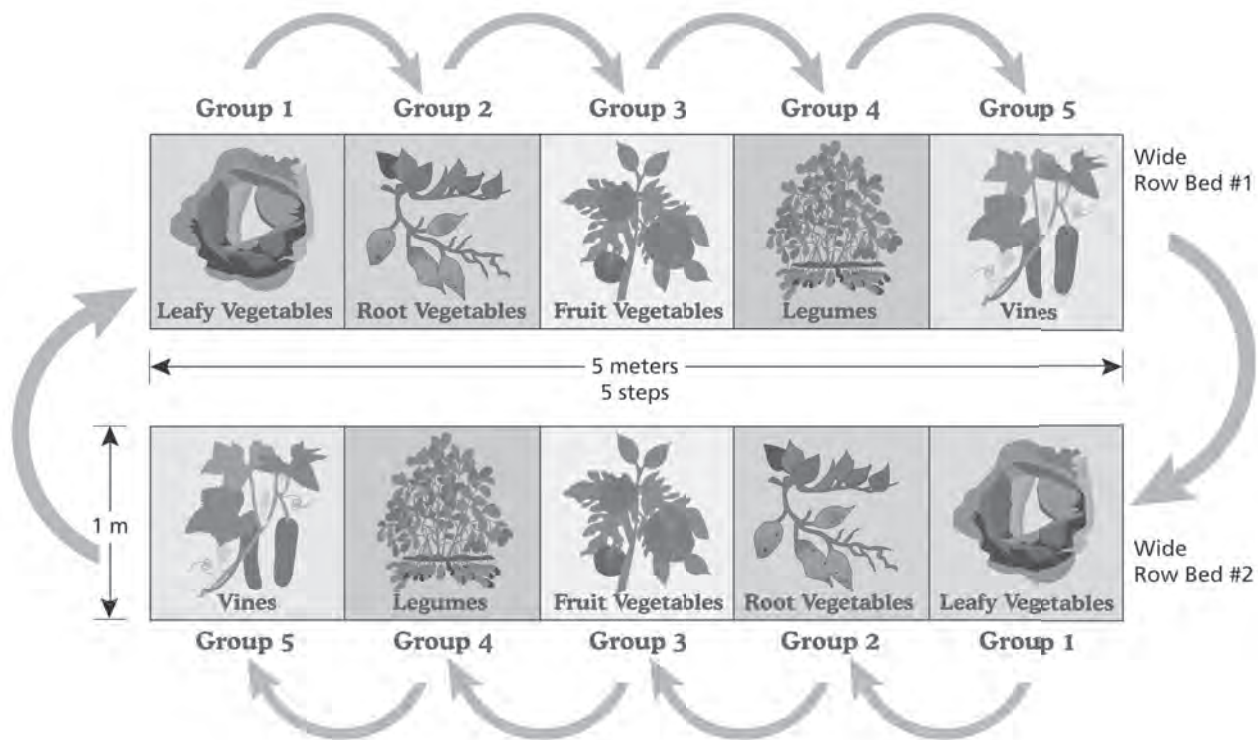

For more information refer to the Manual (Teacher's Guide to School Gardens: Primary School Level).

Teacher's Guide to **Primary** School Gardens: School Level

Organic Solutions to Control Pests and Disease



SOAP SOLUTIONS

are safe and good for soft-bodied insects like aphids. Put one small spoon of soap in 4 liters of water.

HOT PEPPER SOLUTIONS

are a taste repellent and will repel aphids, beetles and thrips. Put 2 small spoons of chopped hot peppers, 2 small spoons of chopped garlic, and 1 small spoon of soap in a liter of water for 24 hours. Strain and dilute with water before using.

BAKING SODA SOLUTIONS

are best for controlling tomato leaf diseases. Mix one small spoon of baking soda and one small spoon of soap in a gallon of water.

ALL SOLUTIONS

Always test a homemade solution before using it.

To make these recipes stronger, add one small spoon of high-quality cooking oil.

To avoid burning the leaves, never treat during the hot and sunny part of the day, especially if the mixture contains oil.

Apply early or late in the day, when insects are less active.

Apply to portions of plants being attacked by pests; reapply after it rains.

*For more information refer to the Manual
(Teacher's Guide to School Gardens: Primary
School Level).*

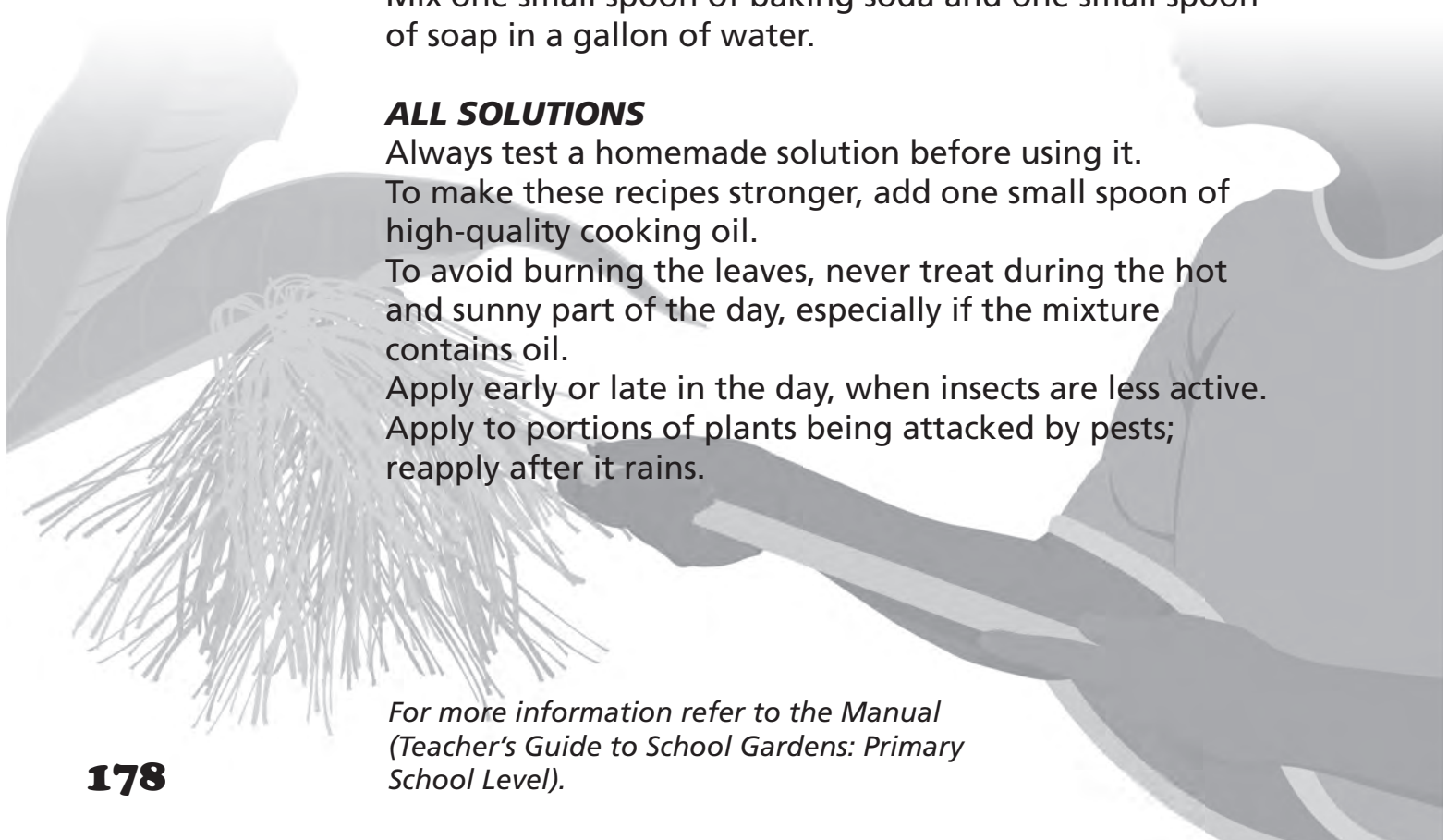

Teacher's Guide to **Primary** School Gardens: **Primary** School Level

Steps to Minimize Diseases of the Tomato Plant



Diseases of the tomato plant include several leaf fungus diseases and soil-borne wilt diseases.

LIVING tomato plants

- ✂ Always stake or tie the tomato plants upright; do not let them grow on the ground.
- ✂ Water only the base of tomato plants, not the leaves.
- ✂ Water tomato plants early in the morning so the leaves dry out.
- ✂ Do not over-water tomato plants. Over-watered plants are more likely to suffer from wet soil wilt diseases.
- ✂ Crop rotation is especially important for tomato plants.

DEAD tomato plants

- ✂ Leaf diseases can exist on old plant debris above ground and/or in the soil.
- ✂ Do not use old tomato plants in the compost pile.

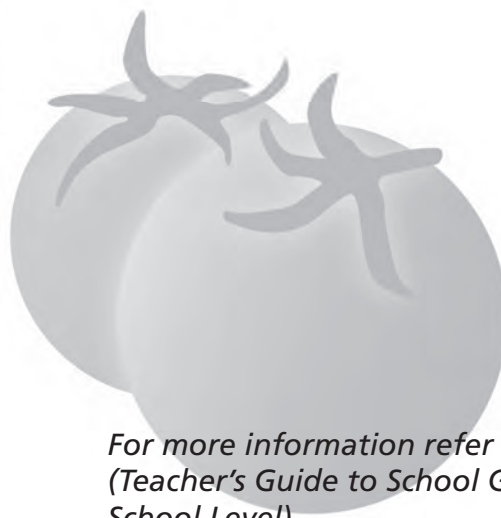
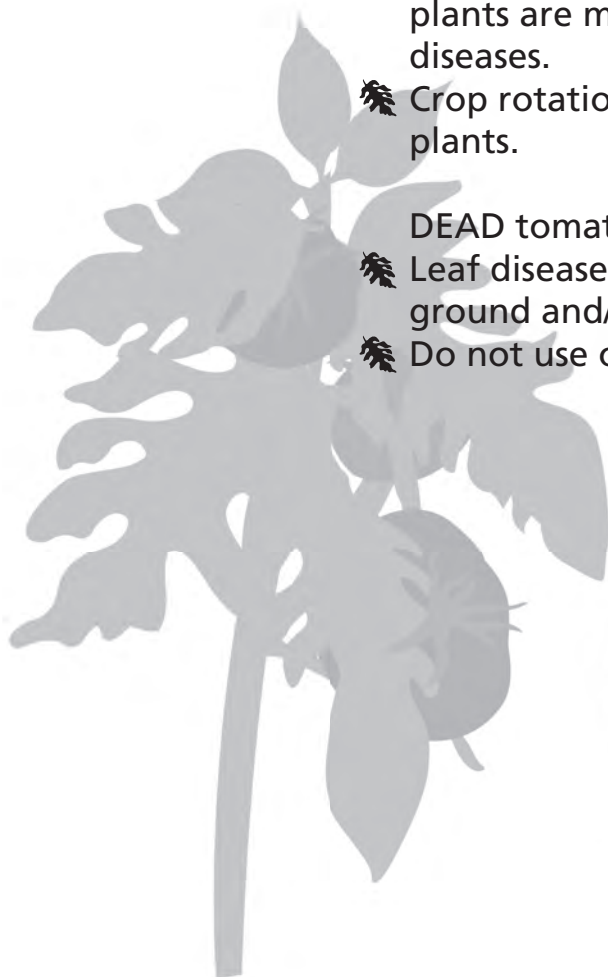

For more information refer to the Manual (Teacher's Guide to School Gardens: Primary School Level).

APPENDIX C: Teacher Training Agendas and Evaluation Instruments

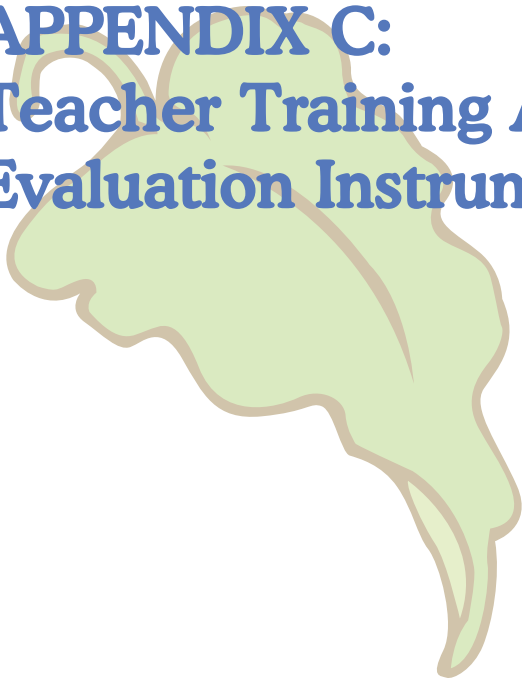

Teacher Training Agenda

Phase I



Day One

7:00	Garden Session	Opening Remarks (Government officials, PTA Leaders of School Site)
8:30	Tea Break and Photo	
9:00	Classroom Session	Overview of Training
1:00	Lunch	
2:00	Garden Session	Basic Steps to Gardening Step 1) Choosing Site Step 2) Site Preparation
3:30	Classroom Session	Wrap up and Process Day

Day Two

7:00	Garden Session	Basic Steps to Gardening Step 3) Planting
9:30	Tea Break	
10:00	Classroom Session	Demonstrating in the garden and classroom
11:00	Garden Session	Basic Steps to Gardening Step 4) Tending the Garden, Mulching
1:00	Lunch	
2:00	Classroom Session	Tools for Teaching in Classroom and Garden Involving students in the garden
3:30	Classroom Session	Wrap up and Process Day

Day Three

7:00	Garden Session	Basic Steps to Gardening Step 5) Harvesting, Composting, Conducting Experiments
9:30	Tea Break	
10:00	Classroom Session	The Garden as a Learning Laboratory Teaching observation skills, doing experiments
12:30	Classroom Session	Nutrition and Food Safety
1:00	Lunch	
2:00	Classroom Session	Bringing the Garden into the Classroom Curriculum Integration, Training Evaluation
3:30	Classroom Session	Closing Ceremony Final Remarks Presentation of Training Certificates

Teacher Training Evaluation Instrument

Phase I

Your evaluation of the school garden training will be used to improve the training and materials for other schools. *Please be honest.* Your answers are anonymous. Please tell us how each part of the training improved your knowledge, if it was useful, and if you are confident in applying what you learned.

For each topic in questions 1-3, circle the number that best represents what you think.

1. Steps in Gardening

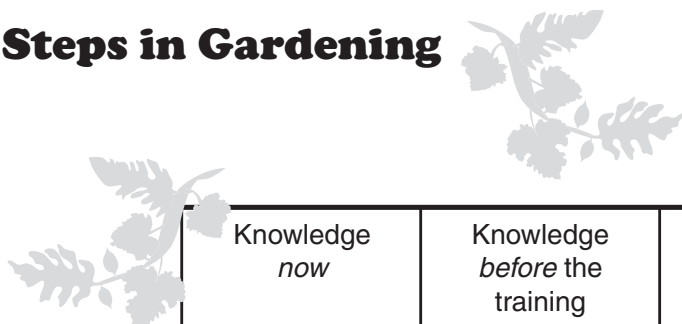

Knowledge <i>now</i>	Knowledge <i>before</i> the training	Usefulness of information or practice	Confidence in using in your classroom
1 = none 2 = little 3 = some 4 = much	1 = none 2 = little 3 = some 4 = much	1 = not useful 2 = a little useful 3 = fairly useful 4 = very useful	1 = none 2 = little 3 = some 4 = much

Topic

Circle the number in each column that best represents your opinion.

Choosing a site	1 2 3 4	1 2 3 4	1 2 3 4	1 2 3 4
Preparing a site	1 2 3 4	1 2 3 4	1 2 3 4	1 2 3 4
Planting	1 2 3 4	1 2 3 4	1 2 3 4	1 2 3 4
Tending	1 2 3 4	1 2 3 4	1 2 3 4	1 2 3 4
Harvesting	1 2 3 4	1 2 3 4	1 2 3 4	1 2 3 4
Garden Calendar	1 2 3 4	1 2 3 4	1 2 3 4	1 2 3 4
Pocket Guide	1 2 3 4	1 2 3 4	1 2 3 4	1 2 3 4

2. Teaching with a School Garden



Knowledge <i>now</i>	Knowledge <i>before the</i> training	Usefulness of information or practice	Confidence in using in your classroom
1 = none 2 = little 3 = some 4 = much	1 = none 2 = little 3 = some 4 = much	1 = not useful 2 = a little useful 3 = fairly useful 4 = very useful	1 = none 2 = little 3 = some 4 = much

Topic

Circle the number in each column that best represents your opinion.

Aims, benefits and elements of School Gardens	1 2 3 4	1 2 3 4	1 2 3 4	1 2 3 4
Planning and managing a garden with your community	1 2 3 4	1 2 3 4	1 2 3 4	1 2 3 4
Experiential learning	1 2 3 4	1 2 3 4	1 2 3 4	1 2 3 4
Demonstration methods	1 2 3 4	1 2 3 4	1 2 3 4	1 2 3 4
How to do an experiment	1 2 3 4	1 2 3 4	1 2 3 4	1 2 3 4
How to involve students in the garden	1 2 3 4	1 2 3 4	1 2 3 4	1 2 3 4
Nutrition	1 2 3 4	1 2 3 4	1 2 3 4	1 2 3 4

3. Classroom Activities and Integration



Knowledge <i>now</i>	Knowledge <i>before</i> the training	Usefulness of information or practice	Confidence in using in your classroom
1 = none 2 = little 3 = some 4 = much	1 = none 2 = little 3 = some 4 = much	1 = not useful 2 = a little useful 3 = fairly useful 4 = very useful	1 = none 2 = little 3 = some 4 = much

Topic

Circle the number in each column that best represents your opinion.

Make instruments such as rain gauges and measuring tapes	1 2 3 4	1 2 3 4	1 2 3 4	1 2 3 4
Use songs, dramas and journals	1 2 3 4	1 2 3 4	1 2 3 4	1 2 3 4
Teach observation skills	1 2 3 4	1 2 3 4	1 2 3 4	1 2 3 4
Integrate activities into French curriculum	1 2 3 4	1 2 3 4	1 2 3 4	1 2 3 4
Integrate activities into Social Studies curriculum	1 2 3 4	1 2 3 4	1 2 3 4	1 2 3 4
Integrate activities into Science curriculum	1 2 3 4	1 2 3 4	1 2 3 4	1 2 3 4

4. The training materials/manual were (check one):

- too easy
- neither too easy nor too difficult
- too difficult

5. The pace of the training was (check one):

- too easy
- neither too easy nor too difficult
- too difficult

6. The best part of the training was:

7. To improve the training I would suggest:

8. Overall, the training (check all that apply):

- will help me start a school garden
- will help our school sustain a school garden
- has overwhelmed me
- was outstanding
- was average
- was poor
- has given me the knowledge and skills I need for a school garden
- was a waste of my time

9. Please tell us about yourself.

For the purpose of this training I am (check all that apply):

- a teacher
- a community member
- a school administrator
- on the parent/school committee

If you are a teacher, how many years have you been teaching? (check one)

- 1-2 years
- 3-5 years
- 6-10 years
- 11 or more years

What is the highest level of formal education you have had? (check one)

- some elementary education
- completed elementary education
- some secondary education but no diploma
- secondary diploma
- some higher education but no degree
- higher education degree

10. Is there anything else you would like to tell us about the training, the manual, or school gardens project? If so, please write your comments here.

Thank you!



Teacher Training Agenda

Phase II



Goals:

Increase teachers' confidence and proficiency in using the garden as a laboratory and integrating it into the standardized curriculum.

Focus on:

- Curriculum integration
- Improving community support and involvement
- Preparing for open door/community education

Day One: School and Community Concerns

8:00	Opening Remarks
8:30	Get acquainted
9:00	Overview and goals for the 4 days
9:30	Experiential learning philosophy and techniques <ul style="list-style-type: none">• Simulations - rainstorm• Songs• "Theory" of experiential learning
11:00	Working with the community
12:30	Planning for Saturday Open Door: What should we teach?
1:00	Lunch
2:00	<ul style="list-style-type: none">• Designing lessons for the garden• Where to use in current curriculum• Ideas for lessons
4:00	Wrap up for the day

Day Two: Practicum - Teaching about the Garden

8:00	Overview of the day
8:15	Preparing/writing lessons <i>Teachers work in teams by school or discipline to prepare an original lesson appropriate to their grade level.</i>
11:00	Teachers present lessons to entire group - critique/feedback
1:00	Lunch
2:00	Preparation for Open Door <i>Teachers prepare demonstrations, make signs.</i>
4:00	Wrap up for the day

Day Three: In the Garden

Water and irrigation techniques

Compost demonstration

Pesticides - natural use - how to make

Green manure demonstration for Saturday

Seeds

How to use the Pocket Guide

Science background in Manual

Other techniques

Continue preparing for Saturday Open Door

Day Four: Open House for Community

3+/- Teachers and students host and demonstrate school lessons
hours Closing ceremony, certificates



Teacher Training Evaluation Instrument Phase II

Your evaluation of the school garden training will be used to improve the training and materials for other schools. *Please be honest.* Your answers are anonymous. Please tell us how each part of the training improved your knowledge, if it was useful, and if you are confident in applying what you learned.

1. Teaching with a School Garden

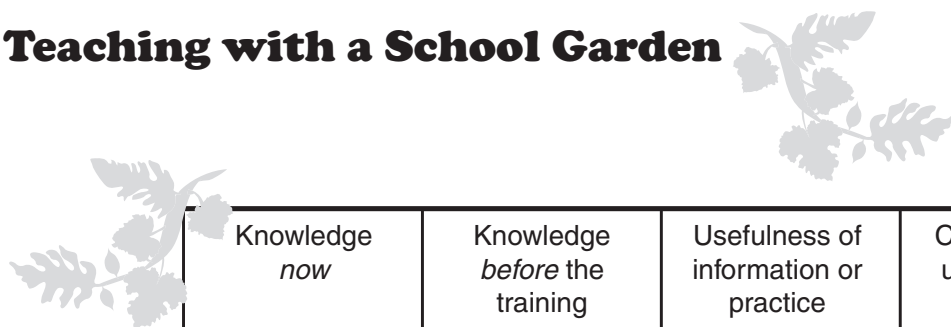

Knowledge <i>now</i>	Knowledge <i>before</i> the training	Usefulness of information or practice	Confidence in using in your classroom
1 = none 2 = little 3 = some 4 = much	1 = none 2 = little 3 = some 4 = much	1 = not useful 2 = a little useful 3 = fairly useful 4 = very useful	1 = none 2 = little 3 = some 4 = much

Topic

Circle the number in each column that best represents your opinion.

Aims, benefits and elements of School Gardens	1 2 3 4	1 2 3 4	1 2 3 4	1 2 3 4
Planning and managing a garden with your community	1 2 3 4	1 2 3 4	1 2 3 4	1 2 3 4
Experiential learning	1 2 3 4	1 2 3 4	1 2 3 4	1 2 3 4
Demonstration methods	1 2 3 4	1 2 3 4	1 2 3 4	1 2 3 4
How to do an experiment	1 2 3 4	1 2 3 4	1 2 3 4	1 2 3 4

2. Classroom Activities and Integration



What did you learn in preparing and developing lessons for your classroom or school?
(Check all that apply):

- how to design a lesson –
set objectives, choose learning activities, etc. for my grade level
- how to insert a garden-related lesson into the national curriculum
- how to adapt a lesson from the gardening manual for my classroom
- how the garden relates to my classroom lessons
- how to work with other teachers for lesson ideas
- how the students will learn better through experiential activities
- none of the lessons in the book apply to what I teach
- nothing
- do not know
- other _____



Will do this <i>now</i>	Did this <i>before</i> the training	Usefulness of information or practice	Confidence in using in your classroom
1 = none 2 = little 3 = some 4 = much	1 = none 2 = little 3 = some 4 = much	1 = not useful 2 = a little useful 3 = fairly useful 4 = very useful	1 = none 2 = little 3 = some 4 = much

Circle the number in each column that best represents your opinion.

Make and use rain gauges	1 2 3 4	1 2 3 4	1 2 3 4	1 2 3 4
Use songs, dramas and journals	1 2 3 4	1 2 3 4	1 2 3 4	1 2 3 4
Teach students how to be good observers in the garden	1 2 3 4	1 2 3 4	1 2 3 4	1 2 3 4
Integrate activities into French curriculum	1 2 3 4	1 2 3 4	1 2 3 4	1 2 3 4
Integrate activities into Social Studies curriculum	1 2 3 4	1 2 3 4	1 2 3 4	1 2 3 4
Integrate activities into Mathematics curriculum	1 2 3 4	1 2 3 4	1 2 3 4	1 2 3 4
Integrate activities into Science curriculum	1 2 3 4	1 2 3 4	1 2 3 4	1 2 3 4

3. How will the community field day help you as a teacher?

If you conduct a community field day, how do you think it will help your school garden?

4. The best part of the training was:

5. To improve the training I would suggest:

6. Overall, the training (check all that apply):

- will help our school sustain a school garden
- will help me be a better teacher using the garden
- has overwhelmed me
- was outstanding
- was average
- was poor
- has given me the knowledge and skills I need for a school garden
- was a waste of my time

7. Please tell us about yourself.

Did you come to the school garden training in 2005? yes no

For the purposes of this training I am (check all that apply):

- a teacher
- a community member
- a school administrator
- on the parent/school committee

If you are a teacher, how many years have you been teaching? (check one)

- 1-2 years
- 3-5 years
- 6-10 years
- 11 or more years

What is the *highest* level of formal education you have had? (check one)

- some elementary education
- completed elementary education
- some secondary education but no diploma
- secondary diploma
- some higher education but no degree
- higher education degree

10. Is there anything else you would like to tell us about the training, the manual, or school gardens project? If so, please write your comments here.

Thank you!



APPENDIX D: Project Monitoring and Evaluation Instruments



School Garden Monitoring Record (NGO) Observation Guide and Evaluation Phase I



Garden Site - Attach garden plan/drawing if available

Name of person completing this report: _____
 Date: _____
 Name of School: _____
 Location of School (village/town): _____
 Number of Students in School: _____
 Number of Pygmy Students in School: _____

Step Progress - *check one* Comments

	Yes	Planning date expected	No	
Site Chosen				Location: (e.g. next to school)
Garden Prepared				By whom? (students, teachers, committee, parents...) Size:
Garden Planted				By whom?
Garden Maintained				By whom? Improvements made:
Vegetables/Fruits Harvested				If yes, list type and amount of food: Use of food: Sold or School Feeding

Other potential progress:

School Garden Committee formed:	NO	YES	If yes, # of people
Developed rules for student garden conduct:	NO	YES	
Students have worked in the garden:	NO	YES	If yes, example of work done:
Teachers incorporated garden in classroom or taught in the garden:	NO	YES	If yes, example: discipline: grade level: # of students:
Other successes			
Need help with:			

School Garden Monitoring Record (NGO) Observation Guide and Evaluation Phase II



Name of person completing this report: _____
 Date: _____
 Name of School: _____
 Location of School (village/town): _____
 Number of Students in School: _____
 Number of Pygmy Students in School: _____

Key Processes and Tasks	Condition/status	Needs Immediate Improvement Yes/No	If improvement needed, plans for next three months
Garden Committee actively involved			
Students working in garden weekly			
Parents involved/supportive			
Effective garden design/size			
Garden perimeter/fence			
Nursery			
Soil preparation			
Composting pits in various stages			
Planting			
Seed germination trials			
Pest management (insects)			
Pest management (fungi)			
Plant health			
Mulching			
Water management			

School Garden Monitoring Record (NGO)

Observation Guide and Evaluation

Phase II, page 2



Key Processes and Tasks	Condition/status	Needs Immediate Improvement Yes/No	If improvement needed, plans for next three months
Plants labeled			
Weeds			
Diversity of plants			
Effective use of produce			
Students aware of how produce is consumed			
Plan for maintenance during vacation			
Recent lessons using the garden - either inside or outside. Be specific (e.g. Level 4, garden vocabulary)			
Recent harvests and disposition (vegetables, amount, sold, or eaten by children, money from sales used for_____)			
Other successes:			
Need help with:			

SECTION IV References



AFRICA: One Continent. Many Worlds.
Website: <http://www.nhm.org/africa/>

American Dietetics Association's Complete Food and Nutrition Guide,
by Roberta Larson Duyff and American Dietetic Association.
Chronimed Publishing, Minneapolis, Minnesota, USA. (1998) (Re-
released 2006 by John Wiley & Sons, Hoboken, New Jersey, USA.)

Basic Seed Saving, by Bill McDorman. International Seed Saving
Institute, Ketchum, Idaho, USA. (1994)
On-line: http://www.seedsave.org/issi/issi_904.html

Building Bridges: Reaching People Through Communication,
Communication Activities for 4-H Clubs and Other Youth Groups, Item
#Comm07, University of Wisconsin–Extension, Madison, Wisconsin,
USA. (No date.)
On-line: <http://learningstore.uwex.edu/>

Companion Planting: Basic Concepts and Resources, by George
Kuepper and Mardi Dodson. National Sustainable Agriculture
Information Service (ATTRA), Fayetteville, Arkansas, USA. Publication
#IP 125/71. (2001)
On-line: <http://attra.ncat.org/attra-pub/PDF/complant.pdf>

Easy Gardening Series, by Dan Lineberger and others. The Agriculture
Program of the Texas Cooperative Extension Horticulture Information
Resource, Texas A&M University System, College Station, Texas, USA.
(Various dates.)
On-line: <http://aggie-horticulture.tamu.edu/extension/gardening.html>

Food Sources of Selected Nutrients. (Appendix B of Dietary Guidelines
for Americans 2005, published by the Department of Health and
Human Services (HHS) and the Department of Agriculture (USDA),
both in Washington, D.C., USA.
On-line: <http://www.health.gov/dietaryguidelines/>

*Got Dirt? A 5-a-day Garden Tool Kit for Implementing Community,
Child Care and School Gardens*. Wisconsin Department of Public
Instruction, Madison, Wisconsin, USA. (2005)
On-line: www.ideas.wisconsin.edu/wyf/gotdirtcomplete.pdf





(A) Guide to Tropical and Sub-Tropical Vegetables, by Nick Acrivos. Brevard Rare Fruit Council, Inc., Melbourne, Florida, USA. (1988)

Handbook of Tropical and Subtropical Horticulture, by Ernest Mortensen and Ervin T. Bullard. Agency for International Development (USAID), Washington, D.C., USA. (1970) (Reprinted by University Press of the Pacific in 2005.)

Harvesting Vegetables, by Erv Evans and Larry Bass. Publication # HIL-8108. North Carolina Cooperative Extension Service, Department of Horticultural Science, North Carolina State University, Raleigh, North Carolina, USA. (1997)

How Food Affects You, Wisconsin Nutrition Education Program. Item #B3479. University of Wisconsin–Extension, Madison, Wisconsin, USA. (2002) On-line: <http://learningstore.uwex.edu/>

Namibian Vegetable Gardener Course, by Frank Wertheim, University of Maine Cooperative Extension, York County Office, Springvale, Maine, USA [and Food and Agriculture Organization of the United Nations (FAO) Rural Youth Development project in Namibia]. (2003)

Nutrition Education in the Primary Schools: A Planning Guide for Curriculum Development (vol.1-The Reader; vol.2-The Activities). Food and Agriculture Organization of the United Nations (FAO), Rome, Italy. (2006)

School Gardens Concept Paper, Special Programme for Food Security. Document # 31, Food and Agriculture Organization of the United Nations (FAO), Rome, Italy. (2004)

Science In Your World Textbook Series, by Jay K. Hackett and Richard H. Moyer. MacMillan-McGraw-Hill School Publishing Company, New York, New York, USA. (1991)

Setting Up and Running a School Garden: A Manual for Teachers, Parents and Communities. Accession No: 431461. Food and Agriculture Organization of the United Nations (FAO), Rome, Italy. (2005) On-line: <http://www.fao.org/docrep/009/a0218e/a0218e00.htm>

Training Trainers for Development: Conducting a Workshop on Participatory Training Techniques. The Centre for Development and Population Activities, Washington, D.C., USA. (1995)
On-line: <http://www.cedpa.org/content/publication/detail/757>

United States Department of Agriculture (USDA) internet web sites:
On-line: www.mypyramid.gov and

(The) Young Virginia Gardener, Virginia Tech, Office of Environmental
Horticulture, Blacksburg, Virginia, USA.
On-line: www.hort.vt.edu/envirohort



SECTION IV

Teacher Observations and Notes

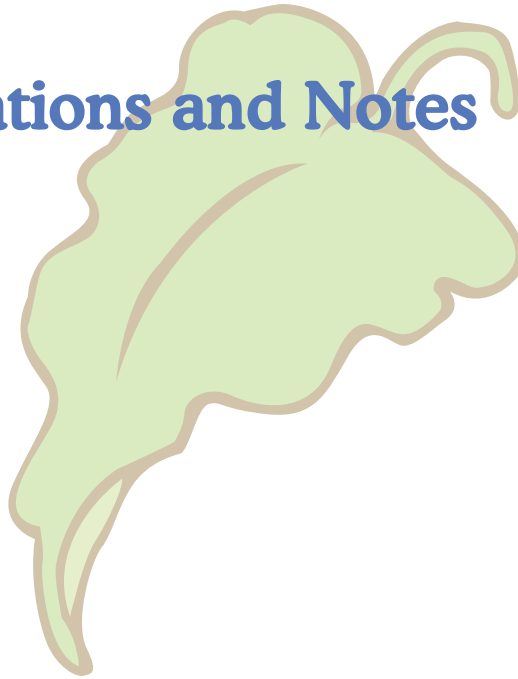

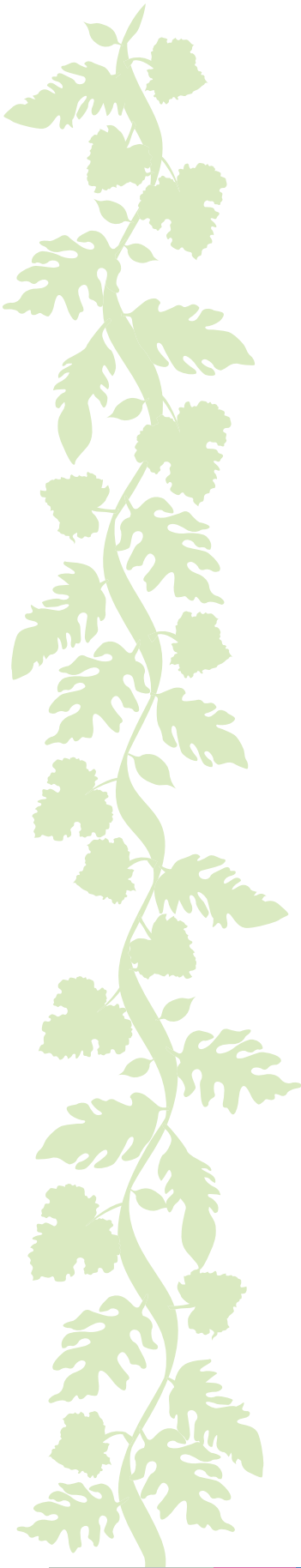







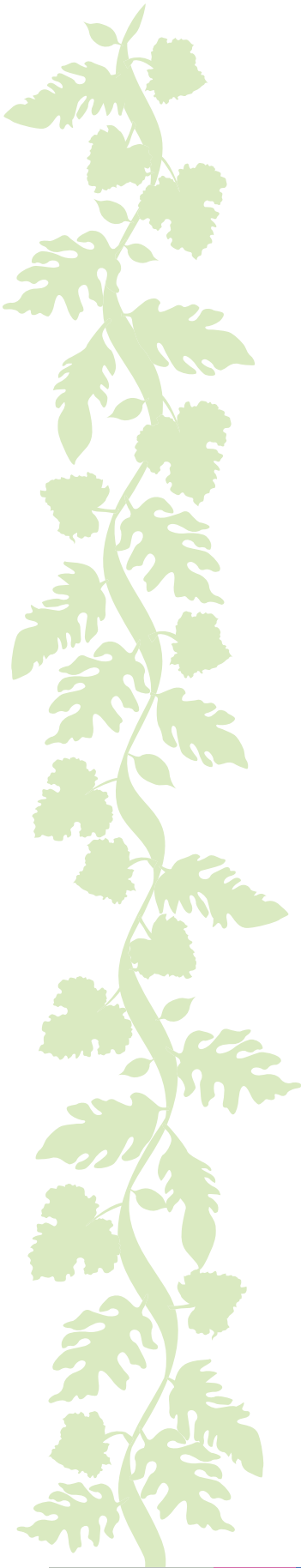







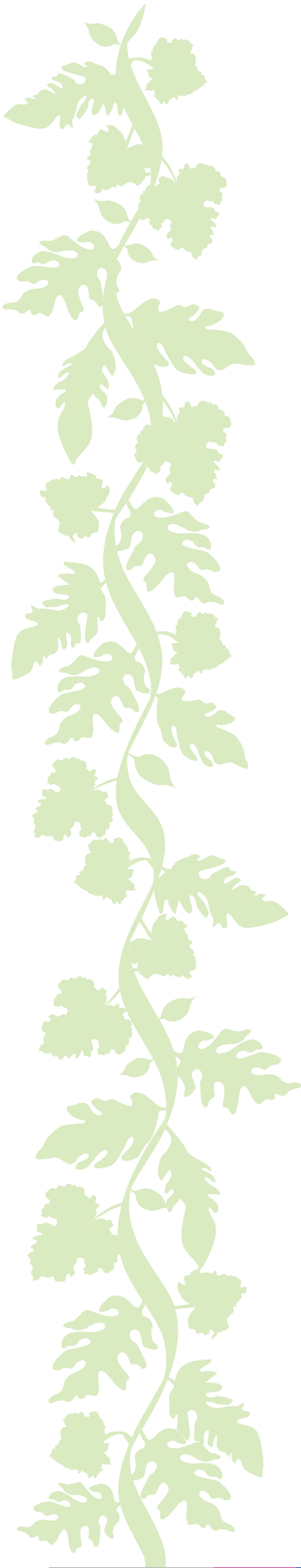

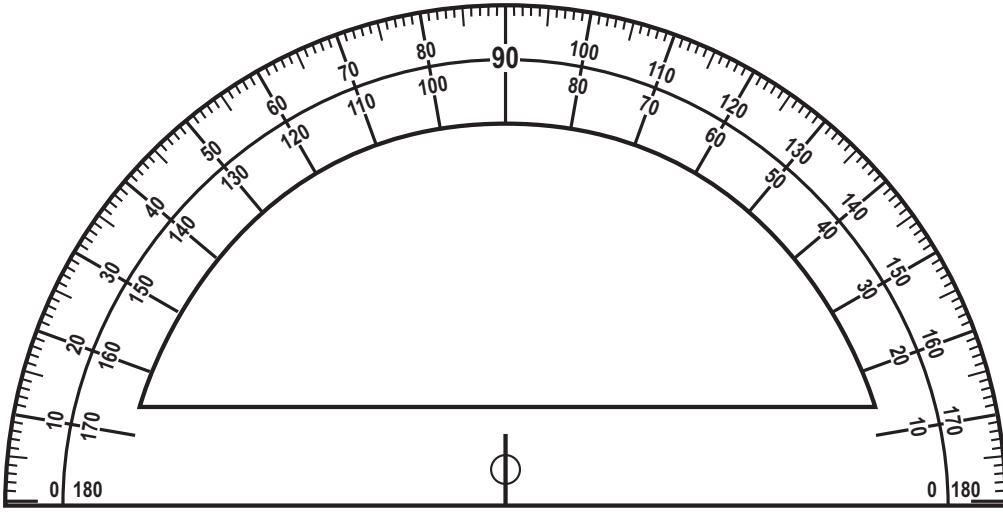

0 1 2 3 4 5 6 7 8 9 10 11 12 13 14 15 16 17 18 19 20 21 22 23 24 25 26



USAID
FROM THE AMERICAN PEOPLE

